

**TIG - GAN**

Brevetto depositato dalla FAMPLA s.n.c. - Italia

Lungh. mm. 115 - Largh. mm. 29 - Lungh. tubetto mm. 80  
 ø esterno mm. 9,80 - ø interno mm. 7,80 - spess. mm. 1,00  
 Portata in trazione senza deformazione kg. 120,00  
 Dimensioni dell'cava: mm. 10,00 x mm. 5,50

(disegno e descrizione tecnico esplicativo)

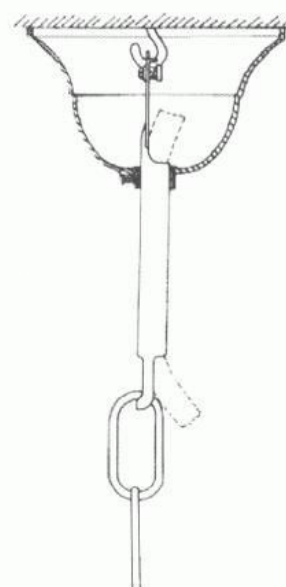
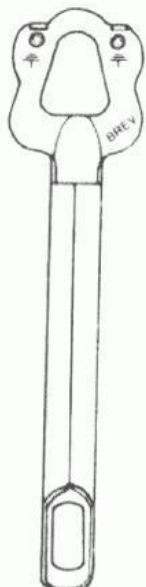

**TIG - GAN**

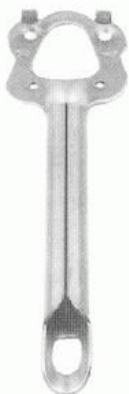

fori superiori fori inferiori

**Art. 290** 2 fori ø 3,5 + 2 fori ø 2,6



fori superiori fori inferiori

**Art. 300** 2 fori 4ma + 2 fori ø 2,6  
 " **306** 2 fori 4ma + 2 fori 3ma  
 " **307** 2 fori ø 3,5 + " " "



fori superiori fori inferiori

**Art. 400** 2 viti 4ma + 2 fori ø 2,6  
 " **401** 1 " " + " " " "  
 " **405** 2 " " + 2 fori 3ma  
 " **406** 1 " " + " " "

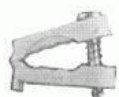

**Art. 1247**  
 bloccacavo  
 con vite  
 auto filettante  
 (articolo Steab  
 codice 5424)



**Art. 1249**  
 bloccacavo  
 in plastica



**Art. 3465**  
 T. Croce 4ma x 6,5 mm  
 ramata



**Art. 3494**  
 T. cacciavite 3ma x 10 mm  
 zincata



Foto  
 dimostrative



Art. 210 - 10/1 Lunghezza 70 GR.  
 " 212 - " " 90 GR.  
 " 213 - " " 100 GR.  
 " 220 - " " 30 ctone

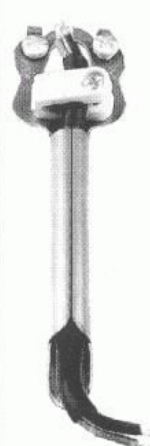

Art. 230 - 10/1 Lunghezza 85 GR.  
 " 231 - " " 95 GR.

Art. 250 - 10/1 Tubetti filettati



I tubetti sono disponibili a partire da mm. 10 fino a mm. 400 con misure intermedie di mm. 5 in mm. 5. Sono inoltre disponibili le misure da mm. 13 e mm. 17. I tubetti si forniscono tropicalizzati.



Art. 255 - 10/1 Tiges filettate  
 Filetti a partire da mm. 5,00



Art. 31050

gommino salva filo per tubetti



Art. 260 - 10/1 Barra filettata

Le barre filettate sono disponibili a mt. 1,0 e mt. 2,0



Art. 270 tubo liscio  $\varnothing$  9.50

I tubi sono disponibili a mt. 1,0 e mt. 2,0



Art. 31080

gommino salva filo per fori  $\varnothing$  10,5

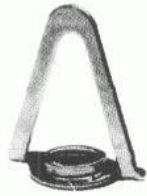

26 x h 30  
Art. 500 - 10/1



27 x h 33  
Art. 600 - 10/1

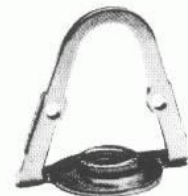

35 x h 34  
Art. 700 - 10/1  
" 730 - 13/1  
" 740 - 1/4 gas



29 x h 29  
Art. 800 - 10/1 3 V.M.



29 x h 29  
Art. 820 - 10/1 1 V.M.  
gancio svezia



30 x h 34  
Art. 850 - 10/1 3 V.M.  
" 870 3 V.M. 2 F. 10,5



35 x h 41  
Art. 900 - 10/1 3 V.M.



35 x h 41  
Art. 901 - 13/1 3 V.M.



35 x h 41  
Art. 902 - 1/4 gas 3 V.M.

Art. 920 3 V.M. 2 F. 10,5



35 x h 41

Art. 921 - 3 V.M. 2 F. 13,5



Art. 950  $\varnothing$  2,40  
" 960  $\varnothing$  3,00

Filo zincato



20 x h 23  
Art. 1000 - 10/1



24 x h 30  
Art. 1100 - 10/1  
" 1150 - 13/1  
" 1151 - 1/4 gas



61 x 18 x 25  
Art. 1180  
gancio inghilterra



14 x 31 x h 6

- Art. 1200 1 F. 10,5 1 V.M.
- " 1201 1 F. 10,5 S.V.
- " 1210 1 F. 4,2 1 V.M.
- " 1211 1 F. 4,2 S.V.



16 x h 33

Art. 1220



16 x 33 x h 5

Art. 1225

con morsetto + vite



16 x 33 x h 5

Art. 1228

con vite



- Art. 1230 foro ø 10 montata
- " 1233 foro ø 10 + vite 4ma + 2 fori 3ma
- " 1234 foro ø 10 + 1 foro 4ma + 2 fori 3ma



- Art. 1240 foro ø 13 + montata
- " 1243 foro ø 13 + vite 4ma + 2 fori 3ma
- " 1244 foro ø 13 + 1 foro 4ma + 2 fori 3ma



Art. 1247  
bloccacavo  
con vite autofilettante  
(Articolo Steab codice 5424)



Art. 3465  
T. Croce 4ma x 6,5 mm  
ramata



Art. 1249  
bloccacavo  
in plastica



Art. 3394  
T. Cacciavite 3ma x 10  
zincata



Art. 1260 - 10/1

anello ø 35 - anello ø 43  
sfera ø 16 - foro passante

ø 15 x h 33



Art. 1270 - 10/1 s/ foro 3ma  
" 1271 - 10/1 con vite

foro passante



ø 14 x h 28

Art. 1280 - 10/1 s/foro 3ma

fusione d'ottone  
foro passante



38 x ø 14 x h 35

Art. 1283 - 10/1 s/ foro 3ma  
" 1284 - 10/1 con vite

fusione d'ottone  
foro passante



38 x h 41

Art. 1286 - 10/1 s/foro 3ma  
" 1286 - 10/1 con vite

foro passante



Art. 1287 s/ foro 3ma + bloccacavo  
" 1288 con vite + bloccacavo

38 x h 41

## ISTRUZIONI

### PER UN CORRETTO UTILIZZO

#### RIFERIMENTO BLOCCAGGIO PER GANCI 1287 - 1288

1. Il dispositivo bloccacavo è progettato per l'utilizzo su apparecchi in classe "L", quindi utilizzare il dispositivo su parti connesse permanentemente a terra.
2. Utilizzare cavo H 03 VV / F 3x0,75 ø max 5,7
3. Utilizzare tiges aventi ø interno min: di mm 6,8 ca
4. Il bloccacavo deve essere utilizzato solo per apparecchi non ricaricabili o su connessioni interne, in quanto, una volta installato, il dispositivo non può essere smontato senza danneggiarlo. E' necessario quindi attenersi alle prescrizioni relative agli apparecchi ricaricabili
5. La temperatura max di esercizio è di 35° centigradi.

Lo stesso dispositivo, brevettato, può essere fornito anche per gli articoli

1270 e 1283

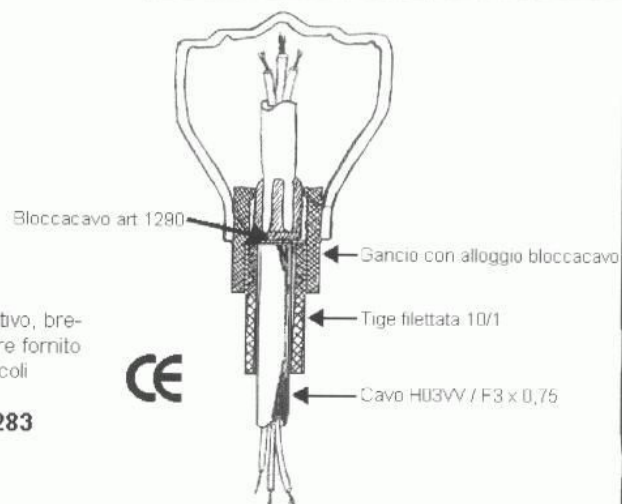



ø 20 x h 18  
Art. 1300 - 10/1



ø 20 x h 18  
Art. 1350 - 10/1  
fusione ottone



ø 26 x h 20  
Art. 1400 - 10/1



ø 20 x h 18  
Art. 1320 - 10/1  
con morsetto + vite

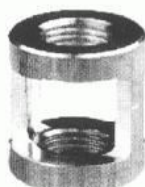

ø 18 x h 20  
Art. 1355 - 10/1  
ottone tornito



ø 26 x h 20  
Art. 1450 - 10/1-4ma



ø 20 x h 20  
Art. 1500 - 10/1



ø 20 x h 20  
Art. 1510 - 13/1  
" 1511 - 1/4 gas



ø 20 x h 20  
Art. 1520 - 10/1-1/4 gas  
" 1530 - 10/1-13/1



Art. 1560 - 10/1  
ø 21 x h 19



ø 18 x h 17  
Art. 1564 - 10/1



Art. 1570 - 10/1  
c/morsetto + bloccatige  
ø 20 x h 20



Art. 1565 - 10/1  
spess. mm. 3,0



Art. 1575 - 10/1  
s/morsetto c/bloccatige

## Dadi tranciati



- Art. 1600 - 10/1 spes. mm. 2,5 chiave 14
- " 1605 - 10/1 spes. mm. 2,5 chiave 13
- " 1624 - 13/1 spes. mm. 3,0 chiave 17
- " 1625 - 13/1 spes. mm. 3,5 chiave 18

## Dadi stampati



- Art. 1622 - 10/1 spes. mm. 3,0 chiave 13
- " 1613 - 10/1 spes. mm. 3,0 chiave 14
- " 1620 - 10/1 spes. mm. 4,0 chiave 13
- " 1615 - 10/1 spes. mm. 4,0 chiave 14
- " 1618 - 10/1 spes. mm. 5,0 chiave 13
- " 1623 - 10/1 spes. mm. 6,0 chiave 13



- " 1619 - 10/1 spes. mm. 4,0 chiave 13 zigrinato



ø 23 x h 4  
Art. 1700 - 10/1



ø 30 x h 4  
Art. 1750 - 10/1



ø 30 x h 1  
Art. 1900 - 10/1



ø 23 x h 1  
Art. 1850 - 10/1



ø 30 x h 4  
Art. 1760 - 10/1



- Art. 1940 spes. mm. 1,0 ø 43 x h 3
  - " 1941 " " 1,5 ø 40 x h 4
  - " 1942 " " 1,5 ø 48 x h 4
  - " 1943 " " 1,5 ø 58 x h 4
- foro ø 10,5

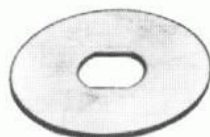

Art. 1945  
ø 30

foro 10,5 x 8,5  
(per tubetti fresati)



ø e	ø i	Art.	ø e	ø i
50	30	1905	xxx	50
60	30	1910	1911	60
70	30	1915	1916	70
80	30	1920	1921	80
90	30	1925	1926	90
100	30	1930	1931	100
120	30	1935	1936	120

spessori disponibili: mm. 1,0 - 2,0

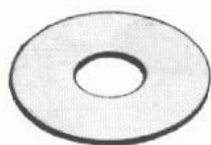

Art. 1950 ø 30 spes. 1,0  
" 1951 ø 30 spes. 2,0  
foro 10,5

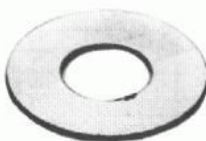

Art. 1960  
ø 30  
foro 13,0



Art. 2000 ø e. 18  
foro 10,5



Art. 2040  
per viti 4ma



Art. 1970  
ø 20  
foro 10,5



Art. 1975  
ø 18  
foro 10,5



Art. 1980  
ø 16  
foro 10,5

Art. 2010 ø e. 14  
foro 10,5

Art. 2050  
per viti 5ma

Art. 2020 ø 23  
foro 13,0

acciaio blu  
e/o zincato C 72



Art. 2300 80 x 0,30  
 " 2310 90 x 0,30  
 acciaio blu C 72

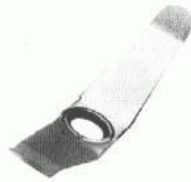

97 x 20 x h 20  
 Art. 2350 C. RAN  
 acciaio blu C 72



97 x 20 x h 20  
 Art. 2360 S. RAN.  
 acciaio blu C 72



ø 92 x h 15  
 Art. 2400 c/ Ran.  
 acciaio blu C 72



	lung. x largh.	
spess. 0,30	mm.	spess. 0,40
Art. 2500	80 x 20	// // //
" 2510	90 x 20	// // //
" 2520	100 x 20	Art. 2600
" 2530	110 x 20	" 2610
" 2540	120 x 20	" 2620
" 2550	130 x 20	" 2630
" 2560	140 x 20	" 2640
" 2570	150 x 20	" 2650
// // //	160 x 20	" 2660
// // //	170 x 20	" 2670
// // //	180 x 20	" 2680
// // //	190 x 20	" 2690
// // //	200 x 20	" 2700

acciaio blu C 72

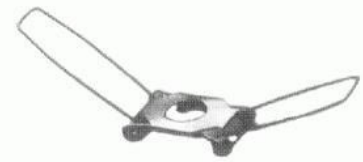

Art. 2800	90 x 17
" 2805	80 x 17
" 2810	100 x 17
" 2820	120 x 17



Art. 2850-10/1	mm. 60	// // //
" 2860-10/1	mm. 80	Art. 2861 foro ø 10,5
" 2870-10/1	mm. 100	" 2871 foro ø 10,5
" 2880-10/1	mm. 120	" 2881 foro ø 10,5
" 2890-10/1	mm. 150	// // //

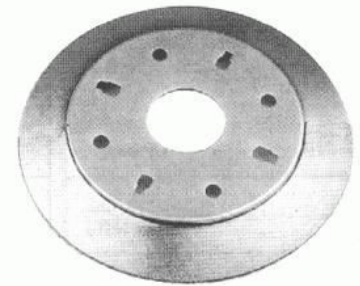

Art. 2895	ø 129	1 f. 10,5
" 2896	" "	" 27,0
" 2897	" "	" 41,0



60 x 20 x 25  
 Art. 2900 - 10/1

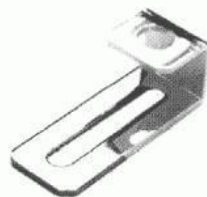













57 x 23 x h 22  
 Art. 2910 - 10/1  
 " 2915 1 f. 10,5

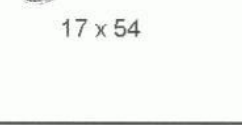

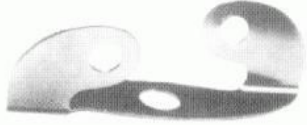

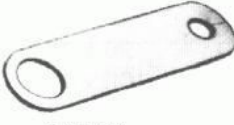

59 x 15 x h 2  
 Art. 2950 1 f. 11,5  
 2 f. 5,5

# Minuterie

 <p>44 x 16 x h 7 Art. 3050</p>	 <p>19 x 61,5 Art. 3260    <p>Art. 3270 C.R.F. " 3271 C.R.F. + 1 V.M.</p> </p>	 <p>ø 42 x h 19 Art. 3300    <p>Art. 3310 C.R.F. " 3312 C.R.F. + 1 V.M.</p> </p>
 <p>Art. 3105 1 foro 9,1 1 " 3,5    <p>Art. 3106 1 foro 9,1 1 " 10,5</p> </p>	 <p>Art. 3115 C.R.F. 1 foro 3,5    <p>Art. 3116 C.R.F. 1 foro 10,5</p> </p>	 <p>23 x 95 x h 30 Art. 3320    <p>Art. 3330 C.R.F. " 3331 C.R.F. + 1 V.M.</p> </p>
 <p>Art. 3200 1 foro 9,1 1 " 3,5    <p>Art. 3220 1 foro 9,1 1 " 5,0</p> </p>	 <p>Art. 3210 C.R.F. 1 foro 3,5    <p>Art. 3230 C.R.F. 1 foro 5,0</p> </p>	

						
Viti testa zigrinata taglio cacciavite	Viti testa cilindrica taglio cacciavite	Viti con taglio a croce		Viti testa cilindrica taglio cacciavite		
filettatura 3ma		filettatura 4ma		filettatura 4ma		
eliminate	Art.	lung. mm. sottotesta	Art.	lung. mm. sottotesta		
	3390	5	3465	6,5		
	3391	6	3407	7,0		
	3394	10	— punta a 90° —			
	3395	12	3466	6,5		
3397	16	3409	7,0	3406	6	
			autoformante	autoformante	3408	8
					3410	10
					3416	16

MISURE, TESTE, LUNGHEZZE e Ø NON RIPORTATE E PER QUANTITA' RICHIEDERE PREVENTIVO

 <p>Art. 3380 plast. nera    <p>Art. 3485 - 4ma " 3486 - 5ma Esagono in ottone ch. 8 x h 11</p> </p>	  <p>Art. 3488 - 3ma ø 8 ottone " 3489 - 4ma ø 10 ottone " 3490 - 4ma ø 12 ottone " 3491 - 10/1 ø 16 ottone " 3492 - 10/1 ø 18 ottone " 3493 - 10/1 ø 20 ottone " 3494 - 10/1 ø 22 ottone " 3495 - 10/1 ø 25 ottone " 3496 - 10/1 ø 30 ottone " 3497 - 10/1 ø 35 ottone</p> <p>su richiesta e per quantità disponibili anche in ferro</p>	 <p>Art. 3498 - 10/1 ø 20 plast. nera " 3499 - 10/1 ø 20 plast. bianca</p>
--	---	---

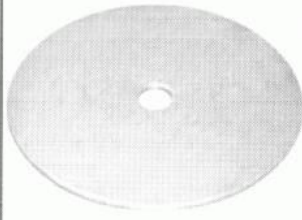
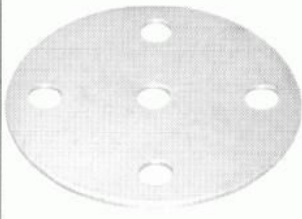
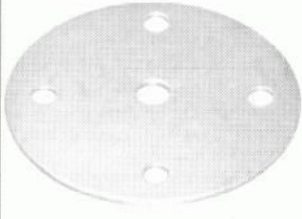
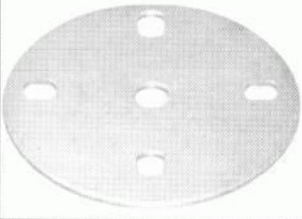
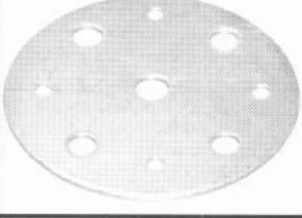
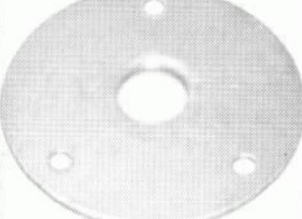
	Art. 3500			Art. 3501	Art. 3610			Art. 3611
	∅ foro	∅ disco	∅ foro		∅ foro	∅ disco	∅ foro	
	10,5	40,0	13,5	Art. 3501	10,5	100,0	13,5	Art. 3611
	" 3510	" 48,0	" "	" 3511	" 3615	" 110,0	" "	" 3616
	" 3520	" 50,0	" "	" 3521	" 3620	" 120,0	" "	" 3621
	" 3525	" 55,0	" "	" 3526	" 3630	" 130,0	" "	" 3631
	" 3527	" 57,5	" "	" 3528	" 3635	" 140,0	xxx	xxx xxxx
	" 3530	" 58,0	" "	" 3531	" 3640	" 148,0	" "	" 3641
	" 3540	" 60,0	" "	" 3541	" 3645	" 150,0	xxx	xxx xxxx
	" 3550	" 65,0	" "	" 3551	" 3650	" 158,0	" "	" 3651
	" 3560	" 70,0	" "	" 3561	" 3655	" 160,0	xxx	xxx xxxx
	" 3570	" 76,5	" "	" 3571	" 3660	" 180,0	" "	" 3661
	" 3580	" 80,0	" "	" 3581	" 3665	" 200,0	xxx	xxx xxxx
	" 3590	" 85,0	" "	" 3591	" 3670	" 210,0	" "	" 3671
	" 3600	" 90,0	" "	" 3601	" 3680	" 245,0	" "	" 3681
" 3605	" 98,0		xxx xxxx					
	disco ∅		f. radiali ∅ 10,5		disco ∅		f. radiali ∅ 10,5	
	Art. 3700	48,0	3	Art. 3760	80,0	2-3-5-6		
	" 3710	50,0	3	" 3770	90,0	2-3-5-6		
	" 3720	58,0	2-3-6	" 3775	98,0	3-5		
	" 3730	60,0	2-3-5-6	" 3780	100,0	2-3-4-5-6-8-10-12		
	" 3740	65,0	2-3-6	" 3785	110,0	2-3-4-5-6-8-10-12		
	" 3750	70,0	2-3-5-6	" 3790	120,0	2-3-4-5-6-8-10-12		
	disco ∅		f. radiali ∅ 8,5		disco ∅		f. radiali ∅ 8,5	
	Art. 3800	70,0	2-3-4	Art. 3820	90,0	2-3-5-6		
	" 3810	80,0	2-3-4	" 3830	100,0	2-3-5-6-8		
	disco ∅		f. radiali fresati 8 x 10,5		disco ∅		f. radiali ∅ 8,5	
	Art. 3840	90,0	3-5	Art. 3820	90,0	2-3-5-6		
" 3850	100,0	5	" 3830	100,0	2-3-5-6-8			
	disco ∅		f. radiali ∅ 8,5 + ∅ 4,5		disco ∅		f. radiali ∅ 4,5	
	Art. 3860	80	3	Art. 3861	80,0	3		
" 3870	100	5-8	" 3871	100,0	3-5			
	disco ∅							
	Art. 3950	120,0	1 f. centrale ∅ 33,5 + 3 f. radiali ∅ 8,0					
	" 3951	120,0	1 f. centrale ∅ 33,5					
" 3952	120,0	1 f. centrale ∅ 10,5 + 3 f. radiali ∅ 8,0						

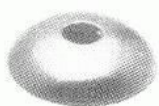

∅ 43 x h 11

Art. 5000



∅ 48 x 7

Art. 5001



Art. 5002 ∅ 55 x h 11 f. 10,5  
" 5002 ∅ 58 x h 7 f. 3,5

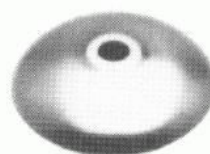

∅ 70 x h 15

Art. 5003



∅ 48 x h 8

Art. 5004  
foro 20 x 20



Art. 5005 75 x h 13 x sp. 1,0 f. 10,5  
" 5006 83 x h 13 x sp. 1,0 f. 10,5  
" 5007 83 x h 18 x sp. 0,7 f. 10,5  
" 5008 83 x h 18 x sp. 1,0 f. 10,5

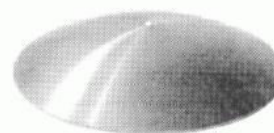

Art. 5009 83 x h 13 x sp. 1,0 f. 8,0  
" 5010 83 x h 13 x sp. 1,0 f. 22,0  
" 5011 90 x h 21 x sp. 1,0 f. 10,5  
" 5012 90 x h 21 x sp. 2,0 f. 10,5

Art. 5013 98 x h 13 x sp. 2,0 f. 10,5  
" 5014 108 x h 15 x sp. 2,0 f. 10,5  
" 5015 108 x h 11 x sp. 1,0 f. 3,5  
" 5016 79 x h 6 x sp. 1,0 f. 3,5  
" 5017 79 x h 6 x sp. 1,0 f. 10,5



∅ e. 70 ∅ i. 50 x h 15 sp. 1,5

Art. 5019



∅ 67 x h 14

Art. 5020



∅ e. 56 ∅ i. 40 x h 8

Art. 5025

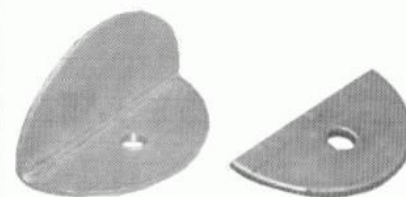

55 x 27 x h 28 sp. 2,0 55 x 27 x sp. 2,0

Art. 5027



Art. 5028

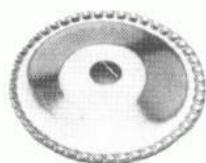

∅ 69 x h 8

Art. 5030



∅ 88 x h 8

Art. 5031

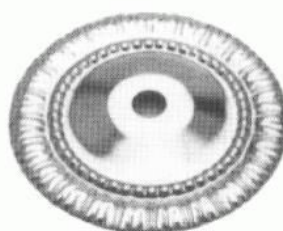

∅ 98 x h 8

Art. 5032

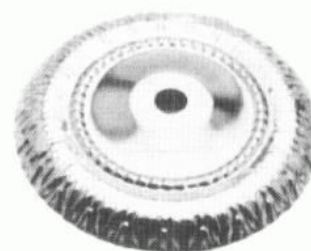

∅ 112 x h 16

Art. 5033

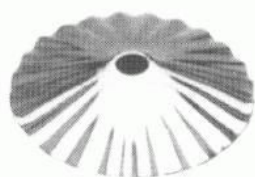

∅ 87 x h 15

Art. 5040 1 f. 10,5  
" 5041 1 f. 3,0

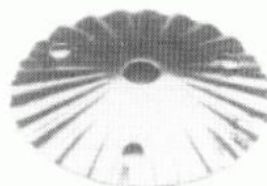

∅ 87 x h 15

Art. 5042

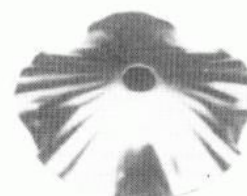

∅ 86 x h 21

Art. 5045

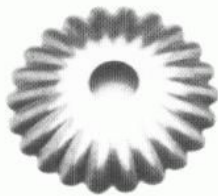

Art. 5050  $\varnothing$  25 x h 3  
" 5051  $\varnothing$  35 x h 6

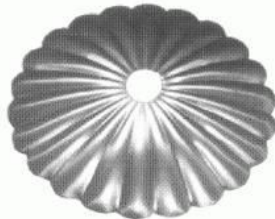

Art. 5052  $\varnothing$  45 x h 6  
" 5053  $\varnothing$  77 x h 10

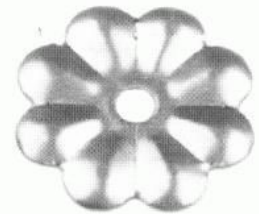

$\varnothing$  66 x h 4  
Art. 5054

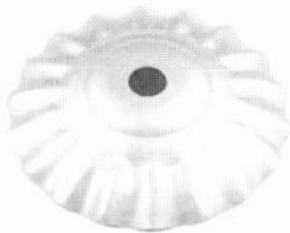

Art. 5065  $\varnothing$  73 x h 17  
" 5066  $\varnothing$  83 x h 17  
" 5067  $\varnothing$  94 x h 18

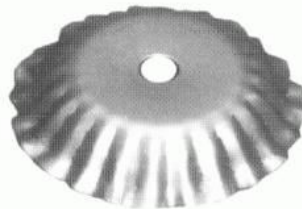

$\varnothing$  e. 82  $\varnothing$  i. 49 x h 17

Art. 5074

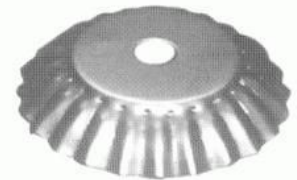

$\varnothing$  e. 70  $\varnothing$  i. 48 x h 15

Art. 5075



Art. 5070  $\varnothing$  73 x h 18  
" 5071  $\varnothing$  80 x h 21  
" 5072  $\varnothing$  87 x h 21



$\varnothing$  e. 75  $\varnothing$  i. 48 x h 19

Art. 5090

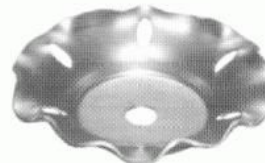

$\varnothing$  e. 94  $\varnothing$  i. 48 x h 22

Art. 5100



Art. 5105  $\varnothing$  75 x h 20  
" 5106  $\varnothing$  88 x h 21

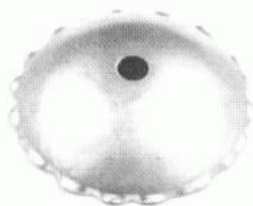

$\varnothing$  94 x h 18  
Art. 5076



$\varnothing$  81 x h 30  
Art. 5110

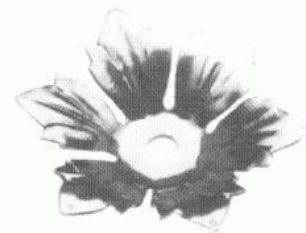

$\varnothing$  96 x h 21  
Art. 5120  
" 5121 6 f. x stss



$\varnothing$  120 x h 29  
Art. 5130

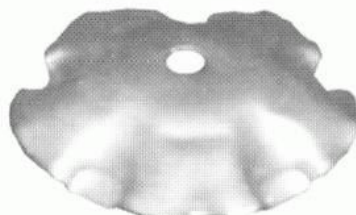

Art. 5140  $\varnothing$  96 x h 17  
" 5141  $\varnothing$  86 x h 17



$\varnothing$  98 x h 16  
Art. 5150

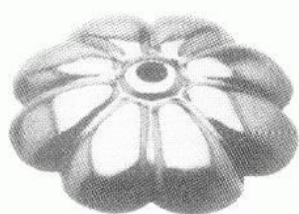

ø 104 x h 19  
Art. 5170

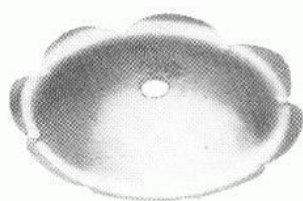

ø 110 x h 17  
Art. 5180

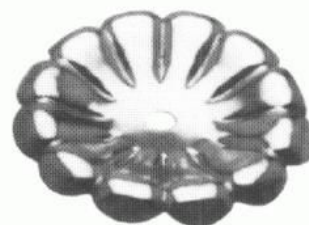

ø 107 x h 13  
Art. 5190

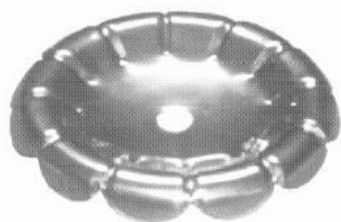

ø 102 x h 14  
Art. 5195



ø 104 x h 19  
Art. 5205

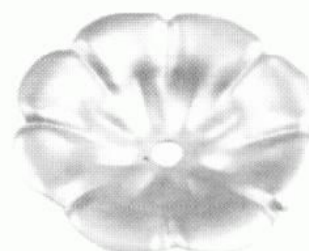

ø 110 x h 17  
Art. 5210



ø 76 x h 21  
Art. 5220

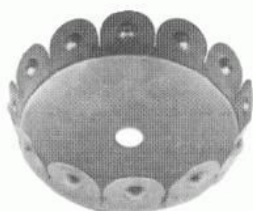

ø 87 x h 26  
Art. 5340



ø 81 x h 22  
Art. 5350

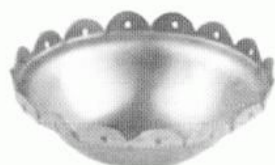

ø 77 x h 29  
Art. 5355



ø 66 x h 8  
Art. 5410

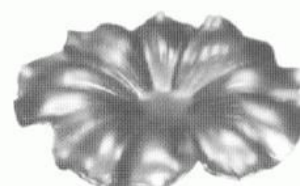

ø 85 x h 10  
Art. 5420



ø 49 x h 7  
Art. 5400



ø 42 x h 14  
Art. 5440



ø 57 x h 12  
Art. 5450

ø 75 x h 12  
Art. 5460

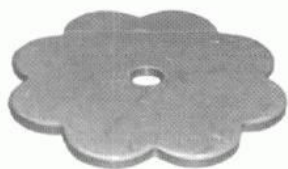

Art. 5055     $\varnothing$  61 sp. mm. 4,0  
" 5057     $\varnothing$  88 sp. mm. 4,0

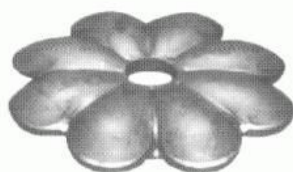

$\varnothing$  60 sp. mm. 4,0  
Art. 5056

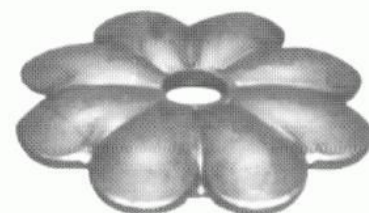

$\varnothing$  86 sp. mm. 4,0  
Art. 5058

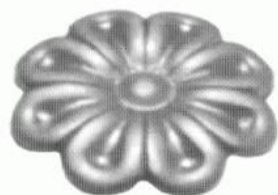

$\varnothing$  60 sp. mm. 2,0  
Art. 5063

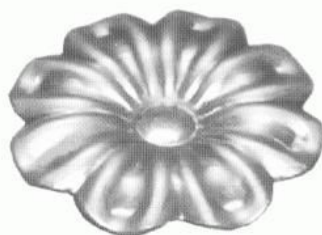

$\varnothing$  68 sp. mm. 2,0  
Art. 5059

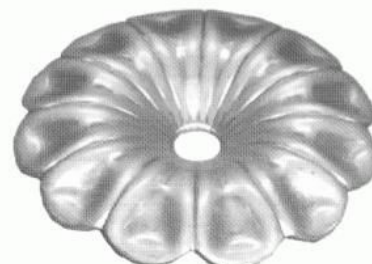

$\varnothing$  90 sp. mm. 2,5  
Art. 5060

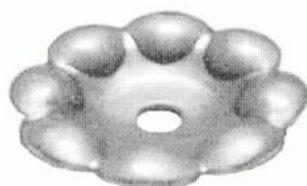

$\varnothing$  66 sp. mm. 2,5  
Art. 5061

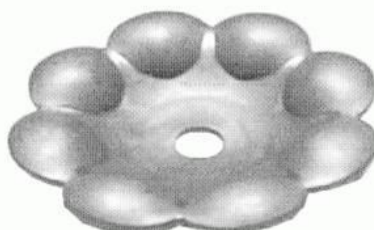

$\varnothing$  84 sp. mm. 2,5  
Art. 5062



$\varnothing$  50 sp. mm. 2,0  
Art. 5470



$\varnothing$  46 sp. mm. 2,0  
Art. 5480



$\varnothing$  60 sp. mm. 2,0  
Art. 5200



$\varnothing$  60 sp. mm. 2,0  
Art. 5203



$\varnothing$  62 sp. mm. 2,0  
Art. 8075



$\varnothing$  81 x h 15 sp. mm. 2,0  
Art. 8105





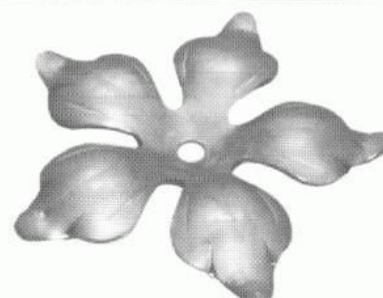





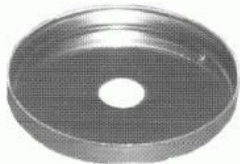



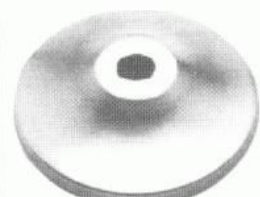

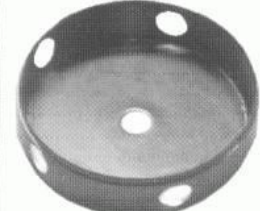
Art. 8108     $\varnothing$  60 sp. mm. 2,0  
" 8109     $\varnothing$  85 sp. mm. 2,0

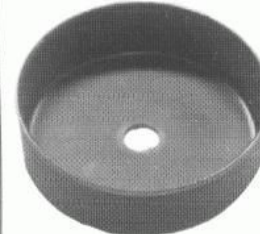

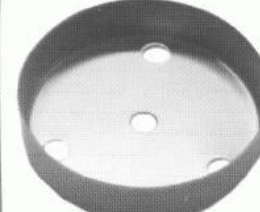
Art. 8106     $\varnothing$  90 x h 10 sp. mm. 2,0  
" 8107     $\varnothing$  140 x h 15 sp. mm. 2,0

# Centratubo - Copricentro - Scatole

 <p>Copritubo</p>	<p>Art. 6000 <math>\varnothing</math> i. 20 x h 7                  " 6001 <math>\varnothing</math> i. 30 x h 7                  " 6002 <math>\varnothing</math> i. 35 x h 7                  " 6003 <math>\varnothing</math> i. 40 x h 7                  " 6004 <math>\varnothing</math> i. 45 x h 7                  " 6005 <math>\varnothing</math> i. 50 x h 7</p>	<p>Art. 6006 <math>\varnothing</math> i. 60 x h 7                  " 6007 <math>\varnothing</math> i. 70 x h 7                  " 6008 <math>\varnothing</math> i. 80 x h 7                  " 6009 <math>\varnothing</math> i. 90 x h 7                  " 6010 <math>\varnothing</math> i. 100 x h 7</p>	 <p><math>\varnothing</math> 70 x h 19                  Art. 6070</p>																															
 <p>Copricentro</p>	<p>Art. 6011 <math>\varnothing</math> i. 48 x h 7                  " 6012 <math>\varnothing</math> i. 58 x h 7                  " 6013 <math>\varnothing</math> i. 68 x h 7                  " 6014 <math>\varnothing</math> i. 78 x h 7</p>	<p>Art. 6015 <math>\varnothing</math> i. 88 x h 7                  " 6016 <math>\varnothing</math> i. 98 x h 7                  " 6017 <math>\varnothing</math> i. 108 x h 7</p>	 <p><math>\varnothing</math> 70 x h 26                  Art. 6075</p>																															
 <p>Copricentro</p>	<p>Art. 6020 <math>\varnothing</math> i. 48 x h 14                  " 6021 <math>\varnothing</math> i. 58 x h 18                  " 6022 <math>\varnothing</math> i. 68 x h 18</p>	<p>Art. 6023 <math>\varnothing</math> i. 78 x h 18                  " 6024 <math>\varnothing</math> i. 88 x h 18                  " 6025 <math>\varnothing</math> i. 98 x h 18</p>	 <p>1 f. 10,5                  Art. 6100  <math>\varnothing</math> 90 x h 26                  Art. 6101                  1 f. 5,0</p>																															
 <p><math>\varnothing</math> fori centr. e rad. mm. 10,5</p>	<table border="1"> <thead> <tr> <th>Art.</th> <th><math>\varnothing</math> e.</th> <th>h</th> <th>n° fori radiali</th> </tr> </thead> <tbody> <tr> <td>Art. 6030</td> <td>50</td> <td>23</td> <td>3-5</td> </tr> <tr> <td>" 6031</td> <td>60</td> <td>23</td> <td>3-4-5-6</td> </tr> <tr> <td>" 6032</td> <td>70</td> <td>23</td> <td>2-3-5-6-4</td> </tr> <tr> <td>" 6033</td> <td>80</td> <td>23</td> <td>2-3-4-5-6-8</td> </tr> <tr> <td>" 6034</td> <td>90</td> <td>23</td> <td>2-3-4-5-6-8-</td> </tr> <tr> <td>" 6035</td> <td>100</td> <td>23</td> <td>2-3-4-5-6-8-10-12</td> </tr> </tbody> </table> <p>calandrate con ribasso</p>	Art.	$\varnothing$ e.	h	n° fori radiali	Art. 6030	50	23	3-5	" 6031	60	23	3-4-5-6	" 6032	70	23	2-3-5-6-4	" 6033	80	23	2-3-4-5-6-8	" 6034	90	23	2-3-4-5-6-8-	" 6035	100	23	2-3-4-5-6-8-10-12	 <p><math>\varnothing</math> 101 x h 22                  Art. 6064</p>				
Art.	$\varnothing$ e.	h	n° fori radiali																															
Art. 6030	50	23	3-5																															
" 6031	60	23	3-4-5-6																															
" 6032	70	23	2-3-5-6-4																															
" 6033	80	23	2-3-4-5-6-8																															
" 6034	90	23	2-3-4-5-6-8-																															
" 6035	100	23	2-3-4-5-6-8-10-12																															
 <p><math>\varnothing</math> foro centrale mm. 10,5</p>	<table border="1"> <thead> <tr> <th>Art.</th> <th><math>\varnothing</math> e.</th> <th>h</th> <th>h</th> </tr> </thead> <tbody> <tr> <td>Art. 6040</td> <td>48</td> <td>h 23</td> <td><math>\neq</math> h 1,2</td> </tr> <tr> <td>" 6041</td> <td>58</td> <td>h 23</td> <td><math>\neq</math> h 1,2</td> </tr> <tr> <td>" 6042</td> <td>68</td> <td>h 23</td> <td><math>\neq</math> h 1,2</td> </tr> <tr> <td>" 6043</td> <td>78</td> <td>h 23</td> <td><math>\neq</math> h 1,5</td> </tr> <tr> <td>" 6044</td> <td>88</td> <td>h 23</td> <td><math>\neq</math> h 1,5</td> </tr> <tr> <td>" 6045</td> <td>98</td> <td>h 23</td> <td><math>\neq</math> h 1,5</td> </tr> <tr> <td>" 6046</td> <td>108</td> <td>h 23</td> <td><math>\neq</math> h 1,5</td> </tr> </tbody> </table>	Art.	$\varnothing$ e.	h	h	Art. 6040	48	h 23	$\neq$ h 1,2	" 6041	58	h 23	$\neq$ h 1,2	" 6042	68	h 23	$\neq$ h 1,2	" 6043	78	h 23	$\neq$ h 1,5	" 6044	88	h 23	$\neq$ h 1,5	" 6045	98	h 23	$\neq$ h 1,5	" 6046	108	h 23	$\neq$ h 1,5	<p><math>\varnothing</math> foro centr. mm. 10,5  <math>\varnothing</math> fori later. mm. 5,0                  con bombatura</p>  <p><math>\varnothing</math> 101 x h 22                  Art. 6064</p>
Art.	$\varnothing$ e.	h	h																															
Art. 6040	48	h 23	$\neq$ h 1,2																															
" 6041	58	h 23	$\neq$ h 1,2																															
" 6042	68	h 23	$\neq$ h 1,2																															
" 6043	78	h 23	$\neq$ h 1,5																															
" 6044	88	h 23	$\neq$ h 1,5																															
" 6045	98	h 23	$\neq$ h 1,5																															
" 6046	108	h 23	$\neq$ h 1,5																															
 <p><math>\varnothing</math> foro radiali mm. 10,5</p>	<table border="1"> <thead> <tr> <th>Art.</th> <th><math>\varnothing</math> e.</th> <th>h</th> <th>n° fori radiali</th> </tr> </thead> <tbody> <tr> <td>Art. 6051</td> <td>58</td> <td>h 23</td> <td><math>\neq</math> h 1,2 3-5</td> </tr> <tr> <td>" 6052</td> <td>68</td> <td>h 23</td> <td><math>\neq</math> h 1,2 2-3-5-6</td> </tr> <tr> <td>" 6053</td> <td>78</td> <td>h 23</td> <td><math>\neq</math> h 1,5 2-3-5-6</td> </tr> <tr> <td>" 6054</td> <td>88</td> <td>h 23</td> <td><math>\neq</math> h 1,5 2-3-5-6</td> </tr> <tr> <td>" 6055</td> <td>98</td> <td>h 23</td> <td><math>\neq</math> h 1,5 2-3-5-6</td> </tr> <tr> <td>" 6056</td> <td>108</td> <td>h 23</td> <td><math>\neq</math> h 1,5 2-3-4-5-6-8-10-12</td> </tr> </tbody> </table>	Art.	$\varnothing$ e.	h	n° fori radiali	Art. 6051	58	h 23	$\neq$ h 1,2 3-5	" 6052	68	h 23	$\neq$ h 1,2 2-3-5-6	" 6053	78	h 23	$\neq$ h 1,5 2-3-5-6	" 6054	88	h 23	$\neq$ h 1,5 2-3-5-6	" 6055	98	h 23	$\neq$ h 1,5 2-3-5-6	" 6056	108	h 23	$\neq$ h 1,5 2-3-4-5-6-8-10-12	<p><math>\varnothing</math> foro centr. mm. 25  <math>\varnothing</math> fori later. mm. 5,0</p>  <p><math>\varnothing</math> 101 x h 22                  Art. 6064</p>				
Art.	$\varnothing$ e.	h	n° fori radiali																															
Art. 6051	58	h 23	$\neq$ h 1,2 3-5																															
" 6052	68	h 23	$\neq$ h 1,2 2-3-5-6																															
" 6053	78	h 23	$\neq$ h 1,5 2-3-5-6																															
" 6054	88	h 23	$\neq$ h 1,5 2-3-5-6																															
" 6055	98	h 23	$\neq$ h 1,5 2-3-5-6																															
" 6056	108	h 23	$\neq$ h 1,5 2-3-4-5-6-8-10-12																															
 <p><math>\varnothing</math> fori radiali mm. 10,5</p>	<table border="1"> <thead> <tr> <th>Art.</th> <th><math>\varnothing</math> e.</th> <th>h</th> <th>n° fori sul bordo</th> </tr> </thead> <tbody> <tr> <td>Art. 6240</td> <td>48</td> <td>h 23</td> <td><math>\neq</math> h 1,2 2-3</td> </tr> <tr> <td>" 6241</td> <td>58</td> <td>h 23</td> <td><math>\neq</math> h 1,2 2-3</td> </tr> <tr> <td>" 6242</td> <td>68</td> <td>h 23</td> <td><math>\neq</math> h 1,2 2-3-4-5</td> </tr> <tr> <td>" 6243</td> <td>78</td> <td>h 23</td> <td><math>\neq</math> h 1,5 2-3-4-5-6</td> </tr> <tr> <td>" 6244</td> <td>88</td> <td>h 23</td> <td><math>\neq</math> h 1,5 2-3-4-5-6</td> </tr> <tr> <td>" 6245</td> <td>98</td> <td>h 23</td> <td><math>\neq</math> h 1,5 2-3-4-5-6-8-10-12</td> </tr> <tr> <td>" 6246</td> <td>108</td> <td>h 23</td> <td><math>\neq</math> h 1,5 2-3-4-5-6-8-10-12</td> </tr> </tbody> </table>	Art.	$\varnothing$ e.	h	n° fori sul bordo	Art. 6240	48	h 23	$\neq$ h 1,2 2-3	" 6241	58	h 23	$\neq$ h 1,2 2-3	" 6242	68	h 23	$\neq$ h 1,2 2-3-4-5	" 6243	78	h 23	$\neq$ h 1,5 2-3-4-5-6	" 6244	88	h 23	$\neq$ h 1,5 2-3-4-5-6	" 6245	98	h 23	$\neq$ h 1,5 2-3-4-5-6-8-10-12	" 6246	108	h 23	$\neq$ h 1,5 2-3-4-5-6-8-10-12	<p><math>\varnothing</math> foro centr. mm. 10,5  <math>\varnothing</math> fori later. mm. 5,0</p>  <p><math>\varnothing</math> 101 x h 22                  Art. 6064</p>
Art.	$\varnothing$ e.	h	n° fori sul bordo																															
Art. 6240	48	h 23	$\neq$ h 1,2 2-3																															
" 6241	58	h 23	$\neq$ h 1,2 2-3																															
" 6242	68	h 23	$\neq$ h 1,2 2-3-4-5																															
" 6243	78	h 23	$\neq$ h 1,5 2-3-4-5-6																															
" 6244	88	h 23	$\neq$ h 1,5 2-3-4-5-6																															
" 6245	98	h 23	$\neq$ h 1,5 2-3-4-5-6-8-10-12																															
" 6246	108	h 23	$\neq$ h 1,5 2-3-4-5-6-8-10-12																															



Art. 6160

ø i. 140 x h 37

Art. 6190

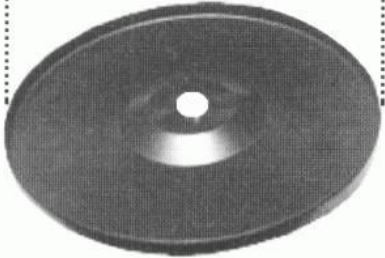
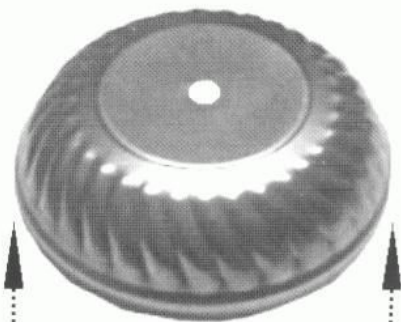

Art. 6170

ø e. 140 x h 8

plastica

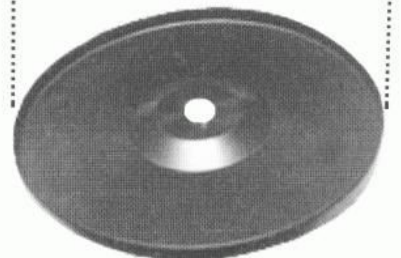

Art. 6150

ø i. 139 x h 37

Art. 6180

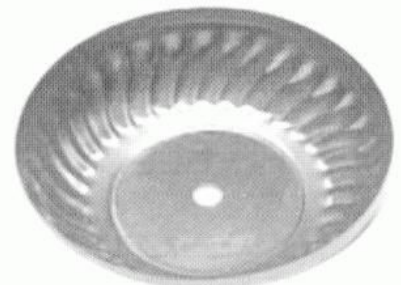

# REGGIVETRO



ø i. 43 x h 33  
Art. 7000



ø i. 53 x h 35  
Art. 7001



ø i. 74 x h 38  
Art. 7002



ø e. 62 ø i. 58 x h 37  
Art. 7040



ø e. 62 ø i. 58 x h 37  
Art. 7050

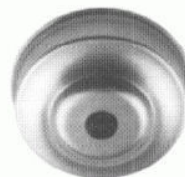

62  
ø e. ø i. 58 x h 24  
Art. 7051

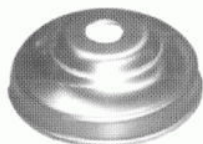

ø i. 56 x h 20  
Art. 7055

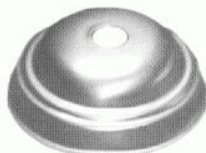

ø i. 58 x h 22  
Art. 7056



ø e. 56 ø i. 52 x h 39  
Art. 7080

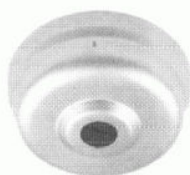

ø 58 x h 26  
Art. 7095

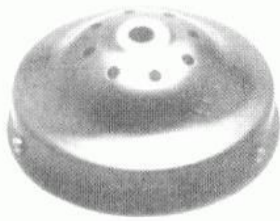

con boccole filettate 3ma		senza boccole	
Art.	Ø i. h	Art.	Ø i. h
Art. 7100	85 40	Art. 7110	85 40
" 7101	90 43	" 7111	90 43
" 7102	95 44	" 7112	95 44
" 7103	105 47	" 7113	105 47
" 7104	120 46	" 7114	120 46
" 7105	130 46	" 7115	130 46



Solo foro centrale	
Art. 7120	Ø 100 x h 35
" 7121	Ø 108 x h 35

con 3 fori da filettare	
Art. 7130	Ø 100 x h 35
" 7131	Ø 108 x h 35

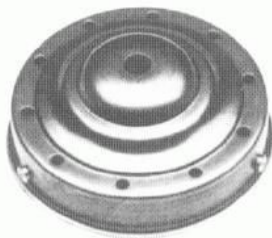

con boccole filettate 3ma		senza boccole	
Art.	Ø i. h	Art.	Ø i. h
Art. 7140	100 42	Art. 7150	100 42
" 7141	110 42	" 7151	110 42

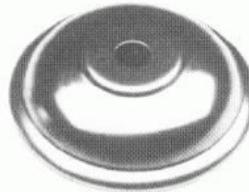

Senza fori di aereazione	
Art. 7160	Ø i. 84 x h 23
" 7161	Ø i. 89 x h 23



Con fori di aereazione	
Art. 7170	Ø i. 84 x h 23
" 7171	Ø i. 89 x h 23

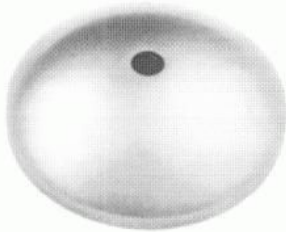

Art. 7200 Ø 90 x h 28  
" 7201 Ø 100 x h 28



Art. 7210 Ø 70 x h 13  
" 7211 Ø 80 x h 14

ribordato



Art. 7220 Ø 80 x h 13

ribordato



Ø i. 58 x h 28  
Art. 7230



Ø i. 58 x h 28  
Art. 7240

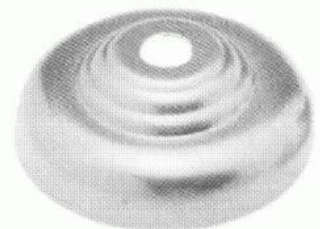

Ø 67 x h 22  
Art. 7250



∅ 55 x h 12

Art. 8001



∅ 46 x h 18

Art. 8002



∅ i. 14 x h 25

Art. 8003



∅ 55 x h 19

Foto dimostrativa



∅ 48 x h 14

Art. 8005



∅ 20 x h 15

Art. 8010



∅ 60 x h 6

Art. 8021



∅ 54 x h 10

Art. 8022



∅ e. 25 ∅ i. 22 x h 25

Art. 8023



∅ 58 x h 23

Art. 8025

saldata



∅ 41 x h 6

Art. 8030



∅ 63 x h 4

Art. 8031

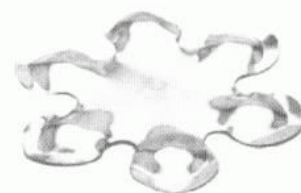

∅ 102 x h 14

Art. 8032



∅ 89 x h 24

Art. 8040



∅ 70 x h 32

Art. 8041



∅ 51 x h 37

Art. 8042



∅ 89 x h 39

Foto dimostrativa



∅ 85

Art. 8055



∅ 67 x h 16

Art. 8057

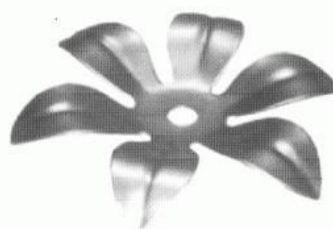

∅ 117 x h 13

Art. 8058



∅ 115 x h 15

Art. 8059



ø 37 x h 4

Art. 8060 senza foro  
" 8061 1 foro 10,5



ø 46

Art. 8065 senza foro  
" 8066 1 foro 10,5

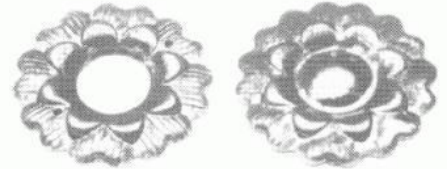

ø 28,5

Art. 8070 1 foro 10,5  
" 8071 2 fori stss



ø 58 x h 6

Art. 8080

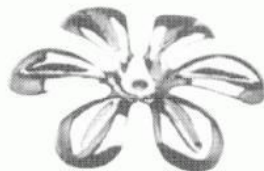

ø 92 x h 6

Art. 8081

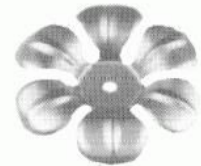

Art. 8082 ø 58 x h 6  
» 8083 ø 85 x h 6

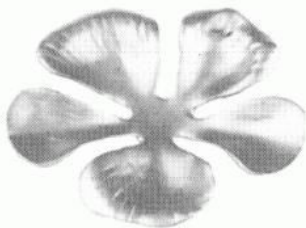

ø 71

Art. 8084

ø 30 x h 83

Art. 8088



ø 33 x h 110

Art. 8086

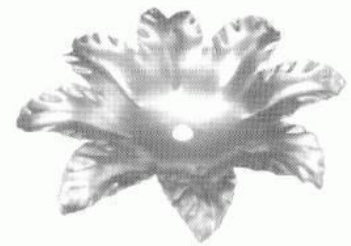

ø 152 x h 27 sp. 1,20

Art. 8090



ø 84 x h 10

Art. 8085

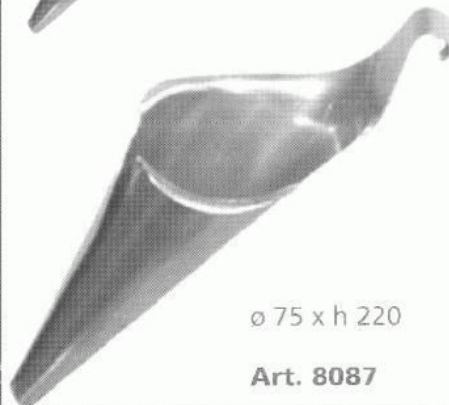

ø 75 x h 220

Art. 8087

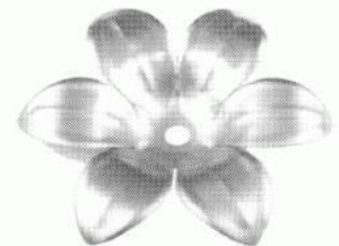

ø 133 x h 20

Art. 8095 6 petali  
» 8096 3 »



ø 58 x h 6

Art. 8100 1 foro ø 4  
» 8101 senza foro

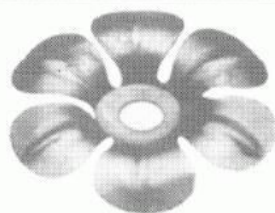

ø 65 x h 9

Art. 8110 1 foro 10,5  
» 8111 senza foro

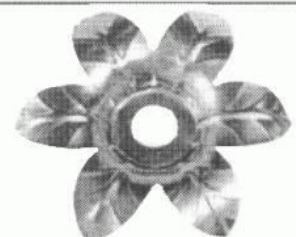

ø 65 x h 9

Art. 8112

Gli articoli 8075 - 8105 - 8106 - 8107 - 8108 - 8109 sono visibili a pag. 13



∅ 105 x h 9  
Art. 8120

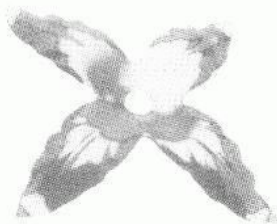

∅ 141 x h 16  
Art. 8130



∅ 109 x h 8  
Art. 8140



∅ 82 x h 14  
Art. 8115

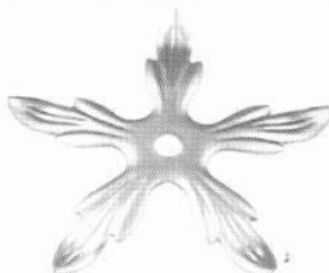

∅ 140  
Art. 8144

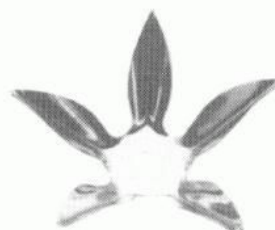

∅ e. 107 ∅ i. 33 x h 32  
Art. 8160

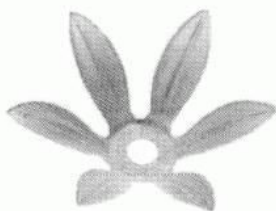

∅ 108 x h 31  
Art. 8162

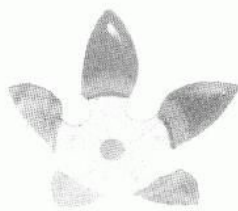

∅ e. 95 ∅ i. 47 x h 31  
Art. 8170



∅ 86 x h 27  
Art. 8175



∅ e. 98 ∅ i. 50 x h 26  
Art. 8180



∅ i. 84 x h 18  
Art. 8190



∅ 56 x h 20  
Art. 8210



∅ 47 x h 26  
Art. 8200



∅ 64 x h 32  
Art. 8205

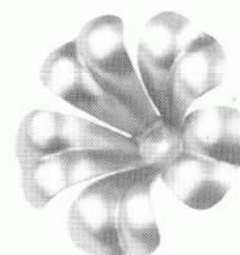

∅ 71 x h 32  
Art. 8206



∅ 40 x h 18

**Art. 8300**

saldata

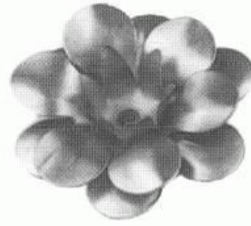

∅ 65 x h 18

**Art. 8320**

saldata

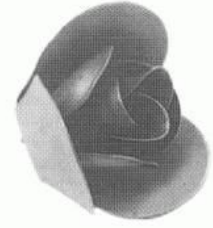

∅ 50 x h 36

**Art. 8340**

con vite 3 x 6

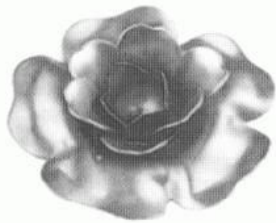

∅ 58 x h 16

**Art. 8310**

saldata



∅ 65 x h 20

**Art. 8330**

saldata

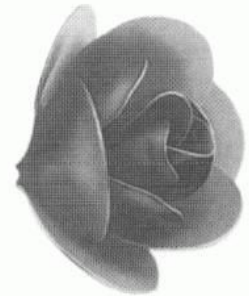

∅ 56 x h 33

**Art. 8350**

con vite 3 x 6



∅ 95 x h 62

**Art. 8360**

saldata



∅ 52 x h 28

**Art. 8370**

saldata



∅ 29 x h 9  
**Art. 9010** 1 foro 10,5  
 " **9011** 1 foro 5,5



∅ 28 x h 11  
**Art. 9020** 1 foro 10,5  
 " **9021** S.F.



∅ 36 x h 21  
**Art. 9030** 1 foro 10,5  
 " **9031** 1 foro 4,0  
 " **9032** S.F.



∅ 30 x h 37  
**Art. 9035**



∅ 37 x h 45  
**Art. 9040**



∅ 33 x h 36  
**Art. 9045**



∅ 66 x h 49  
**Art. 9070**



∅ 50 x h 59  
**Art. 9050**

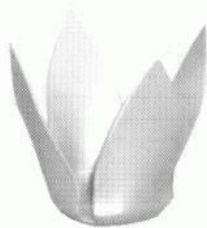

∅ 62 x h 60  
**Art. 9052**



∅ 40 x h 49  
**Art. 9065**



∅ 51 x h 52  
**Art. 9079**



∅ 33 x h 43  
**Art. 9060**



∅ 67 x h 38  
**Art. 9062**



∅ 62 x h 50  
**Art. 9075**



∅ 43 x h 32  
**Art. 9200**



∅ 55 x h 52  
**Art. 9080**



∅ 58 x h 68  
**Art. 9090**



∅ 57 x h 55  
**Art. 9078**

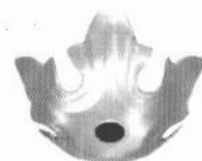

∅ 69 x h 27  
**Art. 9210**



∅ 41 x h 18  
Art. 9100



∅ i. 23 x h 27  
Art. 9102



∅ i 22 x h 26  
Art. 9103



∅ i. 36 x h 30  
Art. 9105



∅ i. 26 x h 26  
Art. 9107



∅ i. 32 x h 25  
Art. 9110



∅ i. 30 x h 56  
Art. 9111



∅ i. 40 x h 61  
Art. 9112



∅ i. 43 x h 34  
Art. 9115



∅ i. 40 x h 38  
Art. 9116



∅ 25 x h 19  
Art. 9118



∅ 33 x h 19  
Art. 9120



∅ 43 x h 26  
Art. 9135



∅ 41 x h 13  
Art. 9145



∅ 58 x h 26  
Art. 9150



∅ 50 x h 30  
Art. 9130

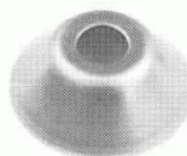

∅ 38 x h 15  
Art. 9140



∅ 65 x h 25  
Art. 9170

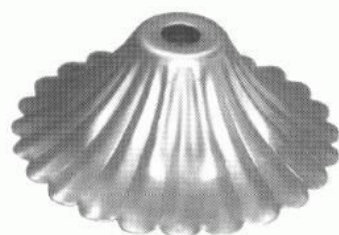

∅ 88 x h 35  
Art. 9160

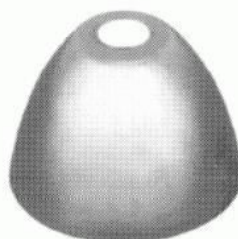

∅ 50 x h 36  
Art. 9180

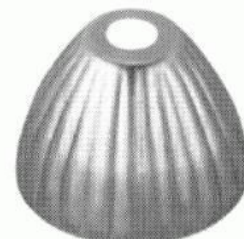

∅ 50 x h 36  
Art. 9190



24 x h 44  
Art. 10000



35 x h 65  
Art. 10001



20 x h 33  
Art. 10005



28 x h 45  
Art. 10006



34 x h 59  
Art. 10007



28 x h 61  
Art. 10008



47 x h 82  
Art. 10011



28 x h 60  
Art. 10014



34 x h 60  
Art. 10015



22 x h 66  
Art. 10016



80 x h 195  
Art. 10020



37 x h 80  
Art. 10021



















29 x h 60  
Art. 10017

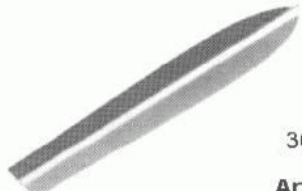
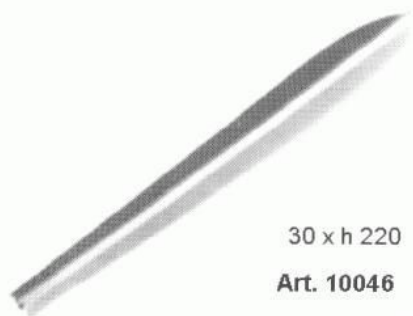

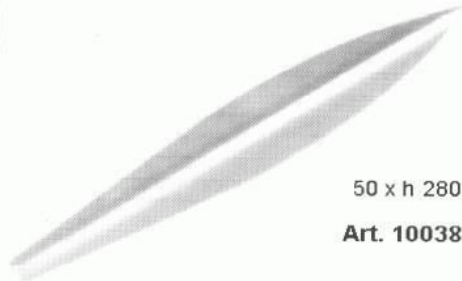
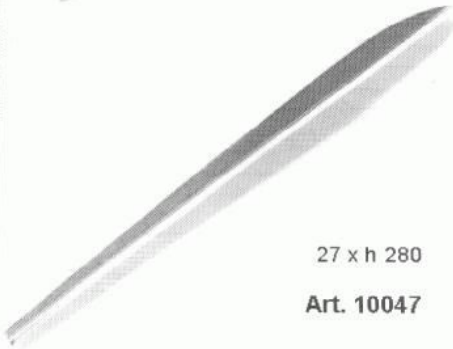
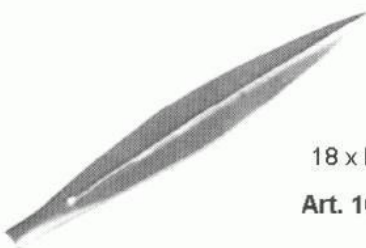
29 x h 60  
Art. 10018

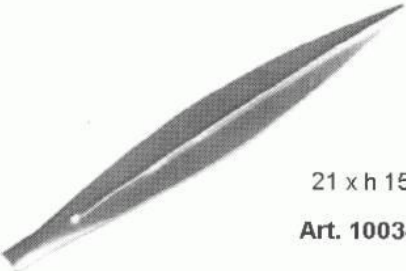

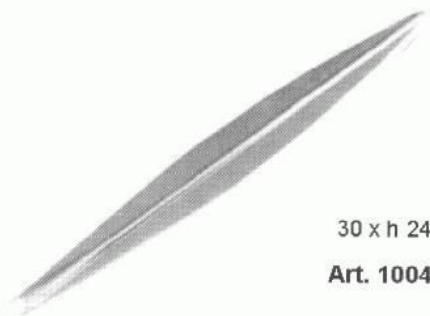
63 x h 60  
Art. 10019

 <p>58 x h 58 Art. 10029</p>	 <p>7 x h 28 Art. 10028</p>  <p>12 x h 50 Art. 10035</p>	 <p>20 x h 90 Art. 10043</p>  <p>25 x h 120 Art. 10044</p>
 <p>12 x h 52 Art. 10030</p>  <p>18 x h 68 Art. 10031</p>	 <p>18 x h 67 Art. 10036</p>  <p>22 x h 75 Art. 10037</p>	 <p>30 x h 150 Art. 10045</p>  <p>30 x h 220 Art. 10046</p>
 <p>16 x h 87 Art. 10032</p>	 <p>50 x h 280 Art. 10038</p>	 <p>27 x h 280 Art. 10047</p>
 <p>18 x h 120 Art. 10033</p>	 <p>20 x h 115 Art. 10040</p>	
 <p>21 x h 150 Art. 10034</p>	 <p>30 x h 163 Art. 10041</p>	
	 <p>30 x h 245 Art. 10042</p>	 <p>Art. 10039 20 x h 280 Art. 10049 20 x h 380</p>



12 x h 97  
Art. 10048



60 x h 155  
Art. 10050



38 x h 79  
Art. 10051

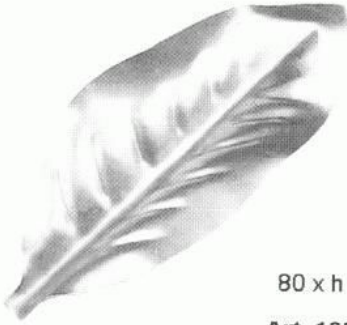

80 x h 180  
Art. 10052



72 x h 210  
Art. 10053



62 x h 135  
Art. 10054



62 x h 150  
Art. 10055



62 x h 134  
Art. 10056

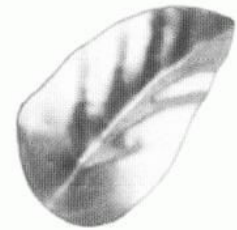

62 x h 106  
Art. 10057



22 x h 56  
Art. 10058



28 x h 70  
Art. 10059



18 x h 88  
Art. 10060



20 x h 72  
Art. 10061



26 x h 89  
Art. 10062



13 x h 93  
Art. 10063



Art. 10064 20 x h 270

Art. 10065 20 x h 380



31 x h 55

Art. 10067



29 x h 55

Art. 10066



44 x h 85

Art. 10068



32 x h 104

Art. 10069



21 x h 120

Art. 10070



24 x h 105

Art. 10071



28 x h 164

Art. 10075

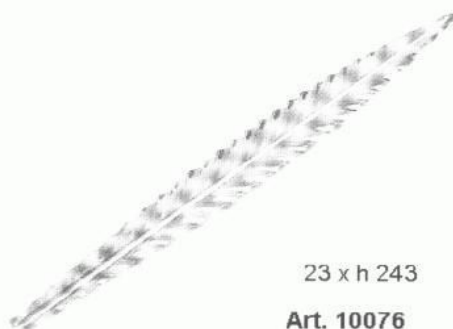

23 x h 243

Art. 10076



48 x h 294

Art. 10079



35 x h 150 sp. 1,80

Art. 10077



50 x h 350 sp. 1,80

Art. 10078



19 x h 200

Art. 10080



31 x h 137  
Art. 10073

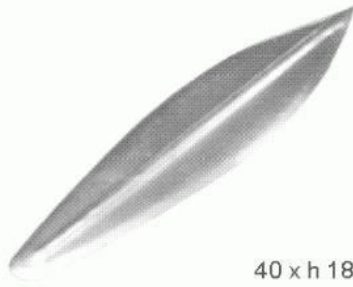

40 x h 181  
Art. 10074



27 x h 74  
Art. 10081

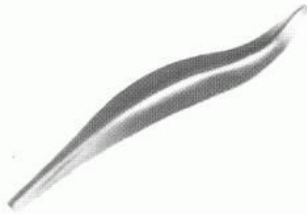

29 x h 165  
Art. 10082



22 x h 135  
Art. 10083



28 x h 150  
Art. 10084



29 x h 160  
Art. 10085



73 x h 200  
Art. 10090 1 foro 10,5  
" 10091 S.F.



73 x h 175  
Art. 10095 1 foro 10,5  
" 10096 S.F.



43 x h 140  
Art. 10086



43 x h 175  
Art. 10087

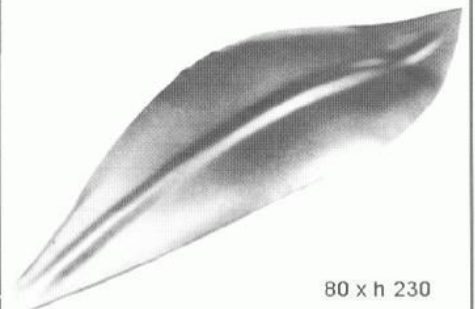

80 x h 230  
Art. 10088



31 x h 72  
Art. 10092



22 x h 51  
Art. 10093

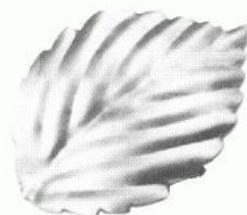

67 x h 93  
Art. 10097



93 x h 126  
Art. 10098



49 x h 63  
Art. 10110



30 x h 32  
Art. 10115



45 x h 59  
Art. 10111



45 x h 49  
Art. 10112



67 x h 71  
Art. 10116



65 x h 85  
Art. 10113

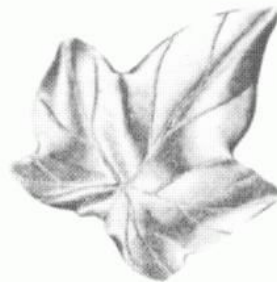

65 x h 70  
Art. 10114



76 x h 65  
Art. 10117



59 x h 48  
Art. 10118



104 x h 86  
Art. 10119



27 x h 28  
Art. 10125



57 x h 57  
Art. 10120



72 x h 72  
Art. 10121



69 x h 65  
Art. 10165



74 x h 76  
Art. 10130



74 x h 76  
Art. 10131



83 x h 85  
Art. 10166



94 x h 97  
Art. 10140



94 x h 97  
Art. 10141

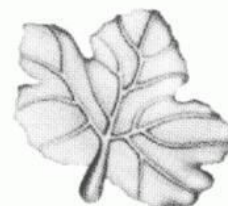

70 x h 65  
Art. 10170



97 x h 91  
Art. 10150



97 x h 91  
Art. 10151



95 x h 107  
Art. 10180



92 x h 91  
Art. 10160



92 x h 91  
Art. 10161



190 x h 195  
Art. 10190



37 x h 95  
Art. 10200



40 x h 123  
Art. 10210

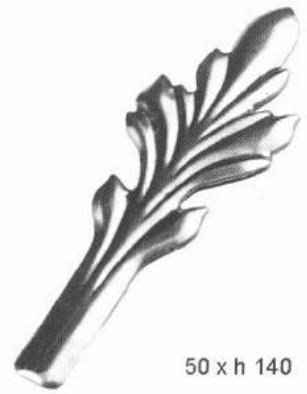

50 x h 140  
Art. 10215



30 x h 62  
Art. 10201



32 x h 87  
Art. 10211



32 x h 136  
Art. 10219



30 x h 82  
Art. 10203



32 x h 120  
Art. 10212



40 x h 170  
Art. 10220



32 x h 90  
Art. 10202



Art. 10230 56 x h 295  
" 10231 56 x h 222



52 x h 81  
Art. 10240



67 x h 89  
Art. 10250



72 x h 125  
Art. 10260



29 x h 86  
Art. 10270



39 x h 103  
Art. 10280



51 x h 133  
Art. 10285



72 x h 220  
Art. 10286



60 x h 60  
Art. 10310



42 x h 63  
Art. 10320

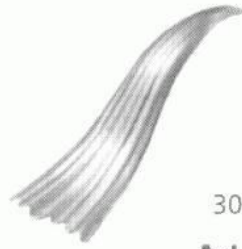

30 x h 100  
Art. 10340

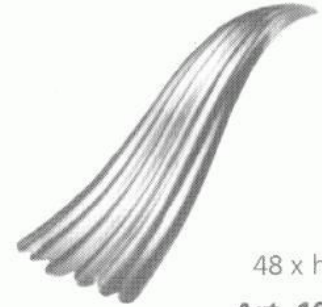

48 x h 150  
Art. 10341



36 x h 167  
Art. 10352 sp. 1,0  
" 10353 sp. 2,0

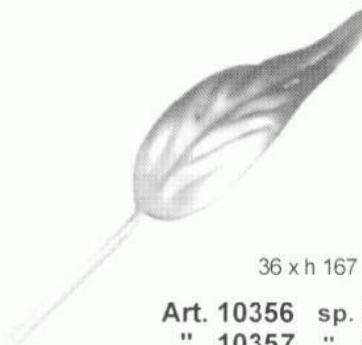

36 x h 167  
Art. 10356 sp. 1,00  
" 10357 " 2,00



Art. 10350 sp. 1,0  
" 10351 " 2,0



36 x h 118  
Art. 10354 sp. 1,00  
" 10355 " 2,00



36 x h 118  
Art. 10358 sp. 1,00  
" 10359 " 2,00



40 x h 90  
Art. 10360  
1 foro 3,0



40 x h 90  
Art. 10361  
S.F.



50 x h 95  
Art. 10400

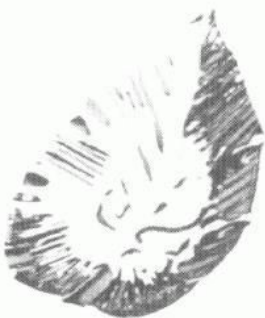

124 x h 170  
Art. 10380



33 x h 64  
Art. 10390

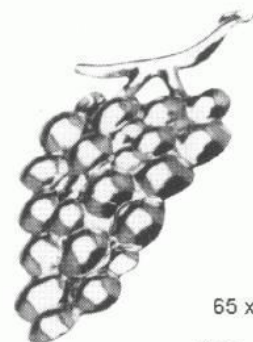

65 x h 130  
Art. 10401



ø 14 x h 55  
**Art. 10409**

foto dimostrativa



18 x h 94  
**Art. 10415**  
destra



18 x h 94  
**Art. 10416**  
sinistra



ø 20 x h 104  
**Art. 10410**

foto dimostrativa

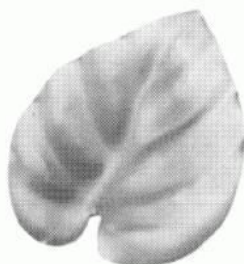

77 x 103  
**Art. 10452**

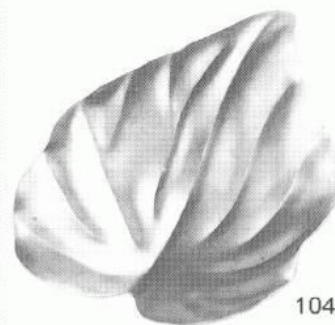

104 x h 127  
**Art. 10453**



27 x h 60  
**Art. 10454**

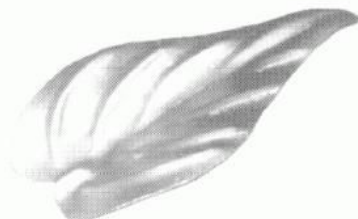

46 x h 93  
**Art. 10455**

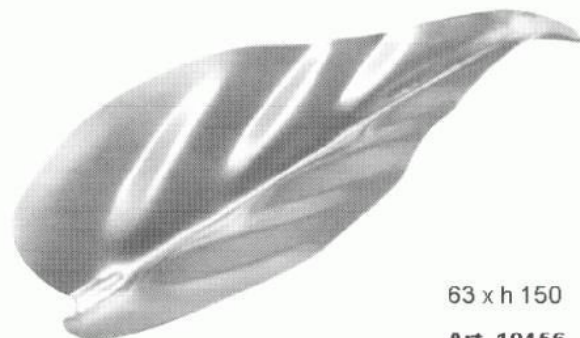

63 x h 150  
**Art. 10456**



40 x h 47  
**Art. 10429**



55 x h 60  
**Art. 10430**



78 x h 78  
**Art. 10431**



40 x h 40  
**Art. 10434**



55 x h 60  
**Art. 10435**



78 x h 78  
**Art. 10436**



34 x h 73  
Art. 10460



48 x h 111  
Art. 10461



25 x h 52  
Art. 10465



38 x h 74  
Art. 10466



52 x h 67  
Art. 10470  
destra



52 x h 67  
Art. 10471  
sinistra



75 x h 120  
Art. 10480  
destra



75 x h 120  
Art. 10481  
sinistra



72 x h 62  
sinistra  
Art. 10490 sp. 2,00  
" 10491 sp. 0,50



72 x h 62  
destra  
Art. 10495 sp. 2,00  
" 10496 sp. 0,50

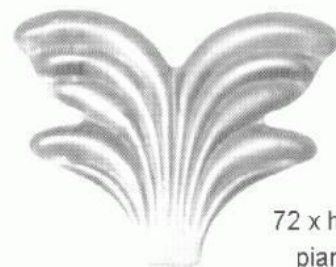

72 x h 62  
piana  
Art. 10498 sp. 2,00  
" 10499 sp. 0,50

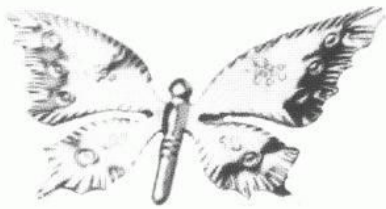

110 x h 63  
Art. 12000

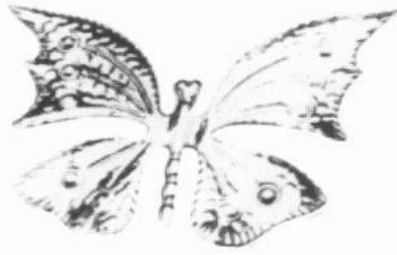

177 x 130  
Art. 12001



ø 56  
Art. 12020 6 f. stss



ø 35  
Art. 12030 1 foro 5,0  
+12 f. stss

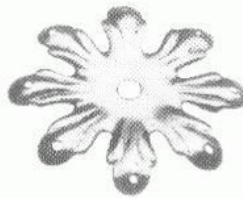

ø 40  
Art. 12050 1 foro 4,0  
+8 f. stss

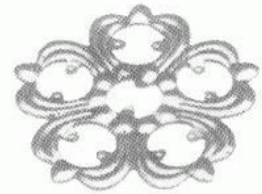

ø 61  
Art. 12080 12 f. stss

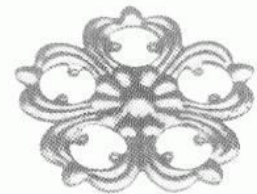

ø 61  
Art. 12081 10 f. stss

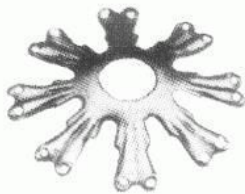

ø 46  
Art. 12040 1 foro 10,5  
" 12041 1 " 5,0  
" 12042 senza foro  
+12 f. stss

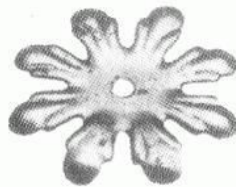

ø 40  
Art. 12051 1 foro 4,0

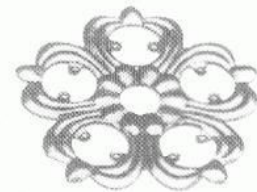

ø 61  
Art. 12082 1 foro 10,5  
" 12083 1 " 5,0  
+12 f. stss



∅ 105 x h 28

Art. 13000



∅ 150 x h 30

Art. 13010



∅ 100 x h 30

Art. 13005 foro 10  
" 13006 " 8



∅ 105 x h 28

Art. 13001 / M

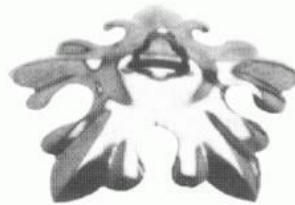

∅ 150 x h 30

Art. 13011 / M



∅ 90 x h 36

Art. 13008



∅ 100 x h 35

Art. 13030

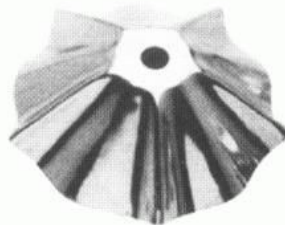

∅ 116 x h 38

Art. 13050



∅ 120 x h 45

Art. 13080 GR.  
" 13081 GR. C.AP.  
" 13081 GR. C.AP. + 1 VM

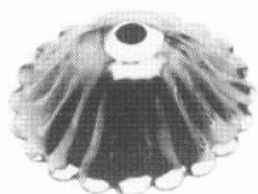

ø 120 X h 43

Art. 13090 GR.  
 " 13091 GR. C.AP.  
 " 13091 GR. C.AP. + 1 VM

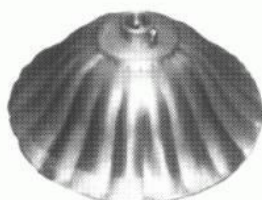

ø 110 x h 40

Art. 13095 GR.  
 " 13096 GR. C.AP.  
 " 13096 GR. C.AP. + 1 VM



ø 90 x h 34

Art. 13130 GR.  
 " 13131 GR. C.AP.  
 " 13131 GR. C.AP. + 1 VM



ø 128 x h 60

Art. 13117 GR.  
 " 13118 GR. C.AP.  
 " 13118 GR. C.AP. + 1 VM



ø 97 x h 53

Art. 13120 CR.  
 " 13121 CR. C.AP.  
 " 13121 CR. C.AP. + 1 VM



ø 118 x h 55

Art. 13125 GR.  
 " 13126 GR. C.AP.  
 " 13126 GR. C.AP. + 1 VM



ø 105 x h 52

Art. 13135 GR.  
 " 13136 GR. C.AP.  
 " 13136 GR. C.AP. + 1 VM  
 " 13137 CR.  
 " 13138 CR. C.AP.  
 " 13138 CR. C.AP. + 1 VM



ø 90 x h 51

Art. 13140 GR.  
 " 13141 GR. C.AP.  
 " 13141 GR. C.AP. + 1 VM  
 " 13142 OT.  
 " 13143 OT. C.AP.  
 " 13143 OT. C.AP. OT. + 1 VM  
 " 13144 CR.  
 " 13145 CR. C.AP.  
 " 13145 CR. C.AP. + 1 VM

ø 110 x h 54

Art. 13150  
 " 13151  
 " 13151  
 " 13152  
 " 13153  
 " 13153  
 " 13154  
 " 13155  
 " 13155



ø e. 129 ø i. 117 x h 52

Art. 13180 GR.  
 " 13181 GR. C.AP.  
 " 13181 GR. C.AP. + 1 VM



	lungh. mm.
<b>Art. 14040</b>	140
" <b>14041</b>	150
" <b>14042</b>	160
" <b>14043</b>	170
" <b>14044</b>	180
" <b>14045</b>	190
" <b>14046</b>	200
" <b>14047</b>	210
" <b>14048</b>	220



	lungh. mm.
<b>Art. 14050</b>	140
" <b>14051</b>	150
" <b>14052</b>	160
" <b>14053</b>	170



160 x 62  
**Art. 14060**



**Art. 14070** 38 x 6,5 x spes. 0,5  
" **14071** 25 x 6,5 x spes. 0,5



160 x h 62  
**Art. 14080**



119 x h 102  
**Art. 14090**



78 x h 157  
**Art. 14130** bollinata



78 x h 157  
**Art. 14131** Incisa



63 x h 52  
**Art. 14150**



22 x h 78  
**Art. 14160**



**Art. 30150** □ 150 x 150 x h 150  
" **30170** □ 170 x 170 x h 190  
con 2 prigionieri saldati

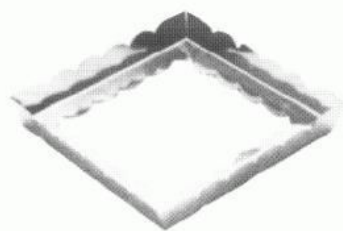

∅ i 88 x 88 x 13,5  
Art. 15000

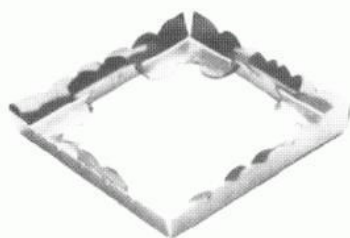

∅ i 88 x 88 x 13,5  
Art. 15001

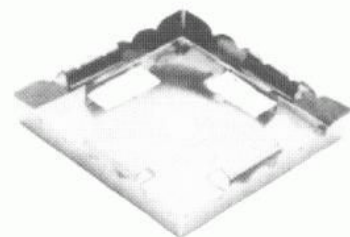

∅ i 88 x 88 x 13,5  
Art. 15002

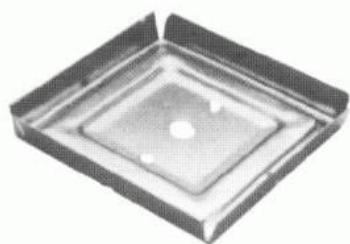

∅ i 100 x 100 x h 16  
Art. 15010

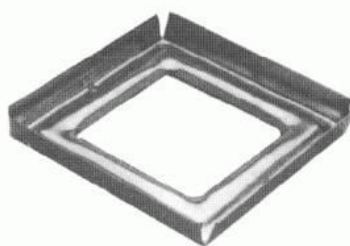

∅ i 100 x 100 x h 16  
Art. 15011

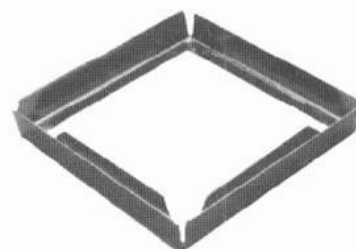

∅ i 100 x 100 x h 16  
Art. 15012

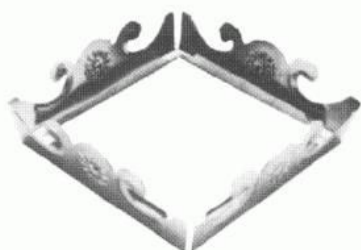

∅ i 110 x 110 x h 30  
Art. 15020

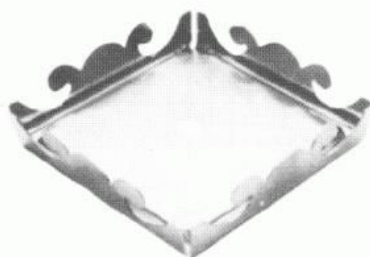

∅ i 110 x 110 x h 30  
Art. 15021

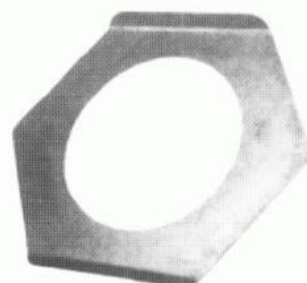

161 x 138  
Art. 15030

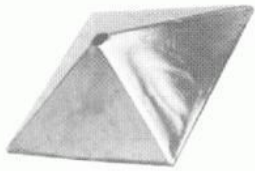

∅ i 111 x 111 x h 33

Art. 16000 1 f. 10,5  
" 16001 senza foro



∅ i 133 x 133 x h 33

Art. 16002 1 f. 10,5  
" 16003 senza foro

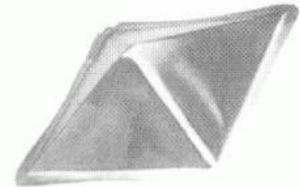

∅ i 131 x 131 x h 33

Art. 16004 1 f. 10,5  
" 16005 senza foro

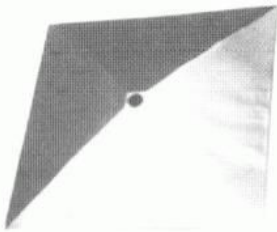

Art. 16020 ∅ i 178 x 178 x h 21  
" 16021 ∅ i 205 x 205 x h 23  
" 16022 ∅ i 225 x 225 x h 26

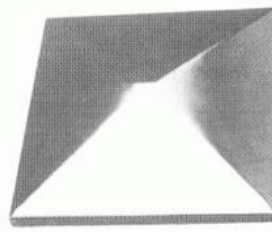

Art. 16030 ∅ i 180x180xh 29 1f. 10,5  
" 16031 ∅ i 180x180xh 29 s/ foro  
" 16032 ∅ i 230x230xh 38 1f. 10,5  
" 16033 ∅ i 230x230xh 38 s/ foro

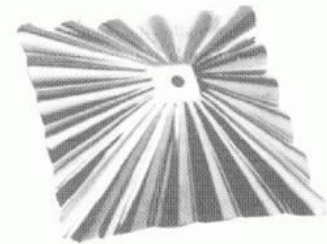

∅  
Art. 16060 125 x 125  
" 16061 170 x 170  
" 16062 200 x 200  
" 16063 230 x 230  
" 16064 240 x 240  
" 16065 265 x 265  
" 16066 101 x 101

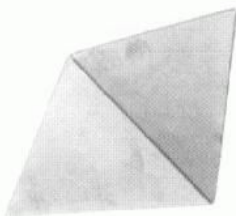

∅ i 183 x 183 x h 83

Art. 16040 Senza foro - S./A.  
" 16041 1 f. 10,5 - S./A.  
" 16042 1 f. 10,5 - S./A. - 2 f. lat. ø 5,0  
" 16043 - S./A. - 2 f. lat. ø 5,0

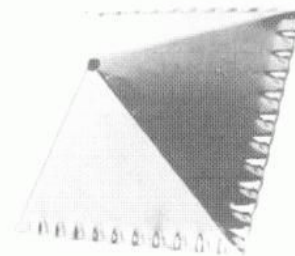

∅ i 205 x 205 x h 96

Art. 16050 senza foro - S./A.  
" 16051 1 f. 10,5 - S./A.

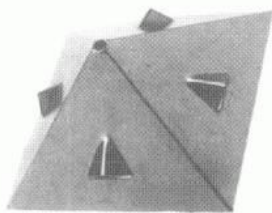

∅ i 183 x 183 x h 86

Art. 16045 senza foro - C./A.  
" 16046 1 f. 10,5 - C./A.  
" 16047 1 f. 10,5 - C./A. - 2 f. lat. ø 5,0  
" 16048 - C./A. - 2 f. lat. ø 5,0

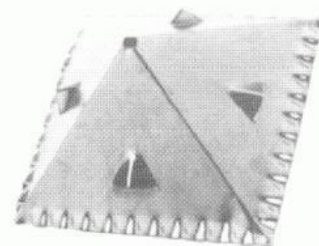

∅ i 205 x 205 x h 96

Art. 16055 senza foro - C./A.  
" 16056 1 f. 10,5 - C./A.

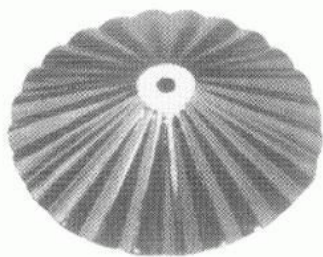

Art. 16080     $\emptyset$  95  
 " 16081    115  
 " 16082    125  
 " 16083    140  
 " 16084    170  
 " 16085    200  
 " 16086    240

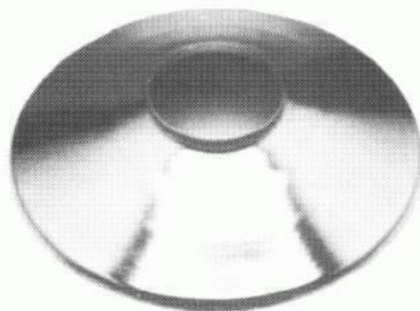

Art. 16110     $\emptyset$  250 x h 100  
 " 16111    1 foro  $\emptyset$  79  
 "            senza foro

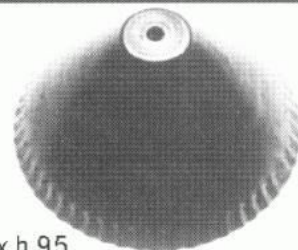

$\emptyset$  182 x h 95

Art. 16120

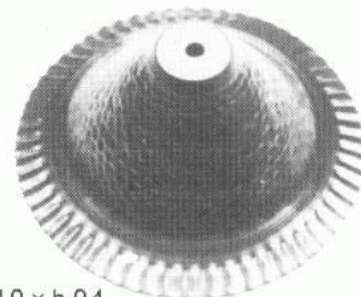

$\emptyset$  210 x h 94

Art. 16130

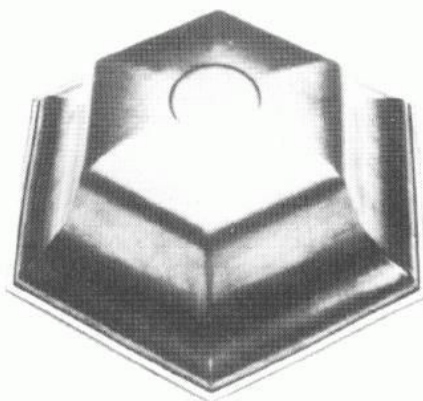

$\emptyset$  250 x h 100

Art. 16100

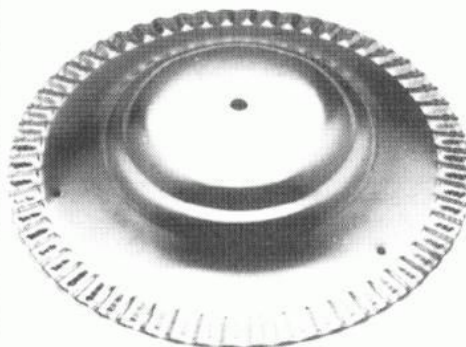

$\emptyset$  289 x h 48

Art. 16140    1 f. 10,5 - 3 f. lat. f. grezzo  
 " 16141                                    - 3 f. lat. f. grezzo  
 " 16142    1 f. 10,5                                ramato

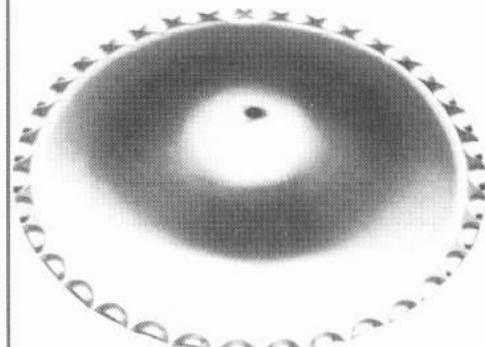

$\emptyset$  320 x h 55

Art. 16150

" 16151 ramato

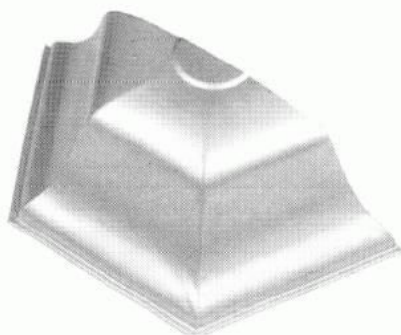

$\emptyset$  250 x h 100

Art. 16105

mezzo esagono

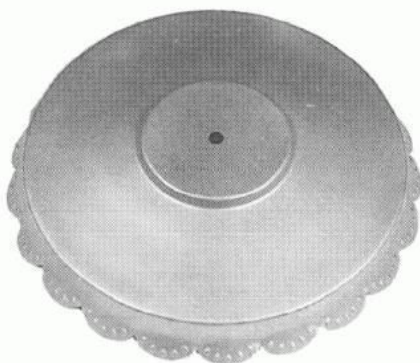

$\emptyset$  270 x h 55

Art. 16160 1f. 10,5 ramato

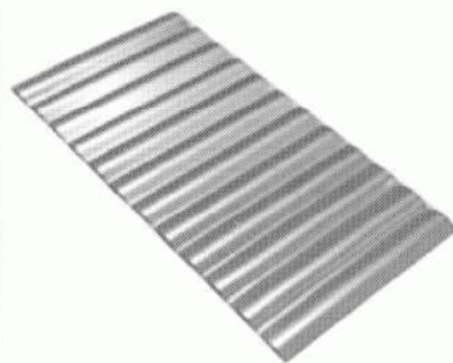

260 x 125

Art. 15600



85 x 53

Art. 17010



132 x 87 x h 18

Art. 17020



82 x 161 x h 15

Art. 17030



200 x 70

Art. 17041



202 x 84

Art. 17050



188 x 140

Art. 17060



197 x 138

Art. 17070

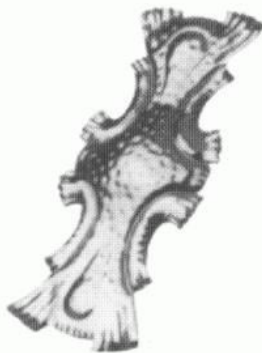

230 x 97

Art. 17080

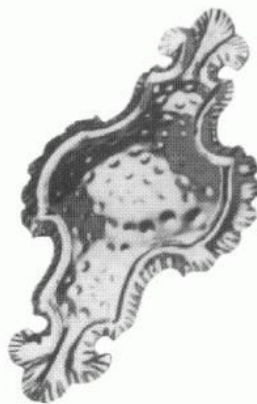

268 x 152

Art. 17090



353 x 132

Art. 17100



124 x 74 x 44 x h 11

**Art. 18000**



120 x 70 x 40 x h 11

**Art. 18001** senza fori  
" **18002** 4 fori  $\varnothing$  4,0



140 x 40 x h 18

**Art. 18020**

lungh. 170 x 31

**Art. 18030**



lungh. 220 x 31

**Art. 18040**

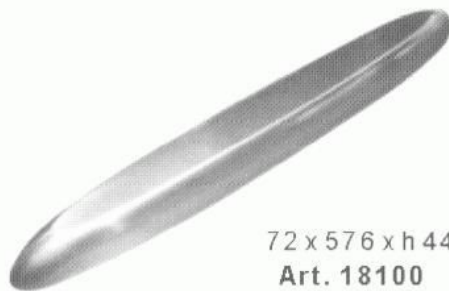

72 x 576 x h 44

**Art. 18100**



70 x 330 x h 44

**Art. 18120**

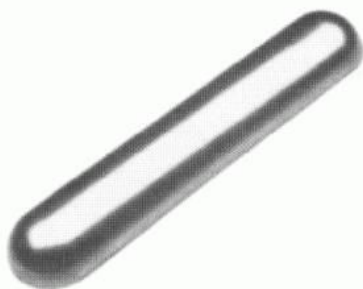

250 x 53 x h 26

**Art. 18050**



75 x 575 x h 26

**Art. 18110**



68 x 332 x h 26

**Art. 18130**

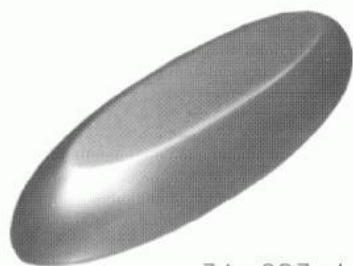

74 x 227 x h 42

**Art. 18140**

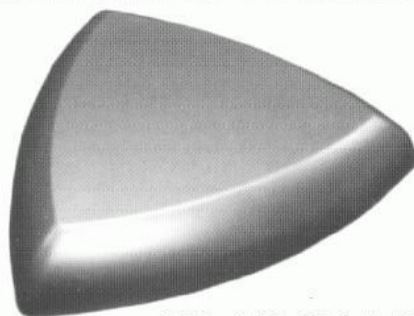

302 x 302 x 302 x h 43

**Art. 18160**



56 x 380 x h 22

**Art. 18180**

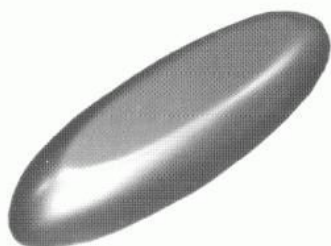

73 x 227 x h 26

**Art. 18150**

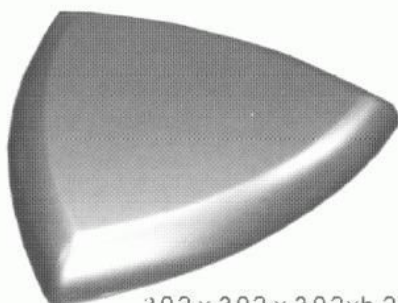

302 x 302 x 302 x h 26

**Art. 18170**

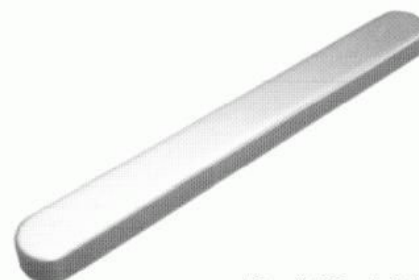

40 x 360 x h 23

**Art. 18190**

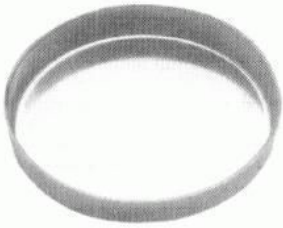

Art. 19000 ø i 78 x h 17 s/bordo  
 " 19001 ø i 78 x h 14 c/bordo  
 " 19010 ø i 98 x h 19 s/bordo  
 " 19011 ø i 98 x h 16 c/bordo  
 " 19020 ø i 106 x h 19 s/bordo  
 " 19021 ø i 106 x h 16 c/bordo



ø i 98 x h 20

Art. 19030

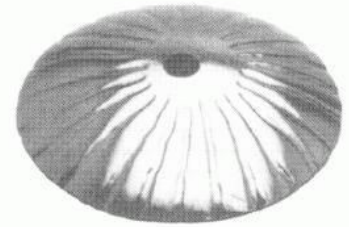

Art. 19080 ø 116 x h 20  
 " 19081 ø 135 x h 35



ø 120 x h 19

Art. 19050 1 f. 10,5  
 " 19051 1 f. 10,5 + 2 f. lat.

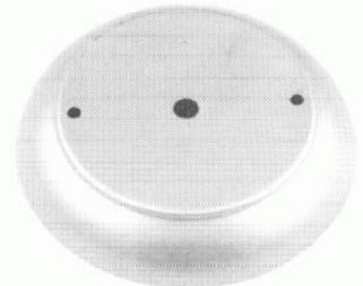

ø 140 x h 24

Art. 19052 1 f. 10,5  
 " 19053 1 f. 10,5 + 2 f. lat  
 " 19054 1 f. 10,5 + 2 f. piano

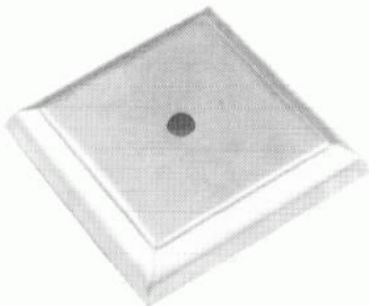

100 x 100 x h 16  
 Art. 19055

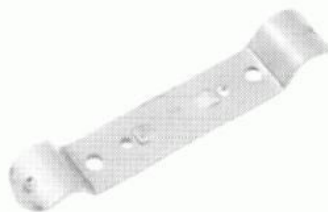

113 x 20 x h 13 sp. 2,0  
 Art. 20055  
 Staffa per art. 19051  
 3 fori filettati 4ma

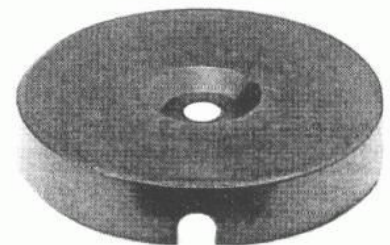

ø 116 x h 20  
 Art. 19060  
 in plastica  
 per art. 19052 e 20245

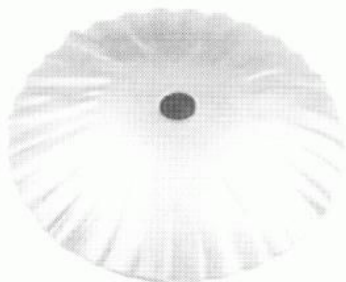

Art. 19090 ø 82 x h 11  
 " 19091 ø 96 x h 16  
 " 19092 ø 105 x h 19  
 " 19093 ø 111 x h 23  
 " 19094 ø 120 x h 26  
 " 19095 ø 134 x h 35  
 " 19096 ø 139 x h 37

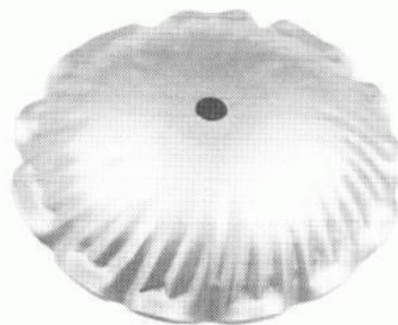

Art. 19097 ø 145 x h 35

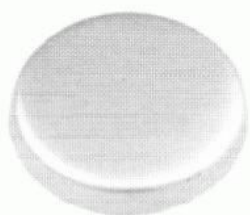

ø e 72 ø i 65 x h 12

Art. 19100

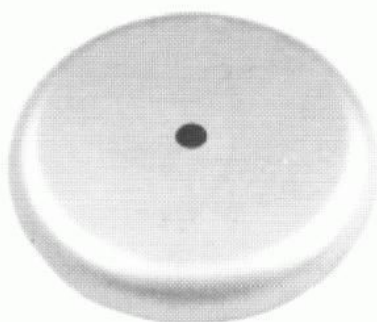

Art. 19120 ø e 150 x h 28  
 " 19121 ø e 130 x h 28  
 " 19122 ø e 100 x h 28  
 " 19123 ø e 175 x h 28  
 " 19124 ø e 200 x h 28

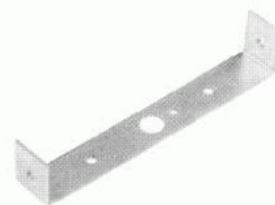

128 x 19 x h 25

Art. 19130 staffa x art. 19120  
 2 fori 4ma

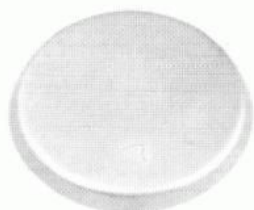

ø e 78 ø i 72 x h 7

Art. 19110

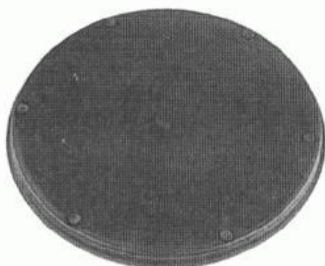

Art. 19125 x art. 19120  
 " 19126 x art. 19121  
 " 19127 x art. 19122  
 " 19128 x art. 19123  
 " 19129 x art. 19124

sottobase in plastica



111 x 19 x h 25

Art. 19131 staffa x art. 19121  
 2 fori 4ma



ø 86 x h 25

Art. 19200 1 f. 10 + 2 f. 5  
 " 19201 1 f. 10



88 x 44 x h 22

Art. 19250



82 x 15 x sp. 1,5

Art 19251



80 x 19 x h 26

Art. 19132 staffa x art. 19122  
 2 fori 4ma



ø 150 x h 36  
Art. 20000



ø 121 x h 13  
Art. 20020 f.c. ø 76,0  
" 20021 f.c. ø 10,5  
" 20022 senza foro

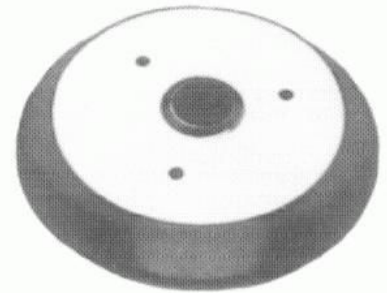

ø 200 x h 34  
Art. 20030 f.c. ø 32  
" 20031 f.c. ø 32 + 3 f. lat.  
" 20032 senza foro

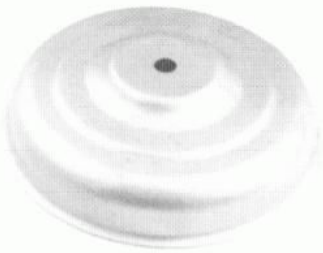

Art. 20025 ø 170 x h 45 spes. 1,5  
" 20026 ø 170 x h 45 spes. 0,6

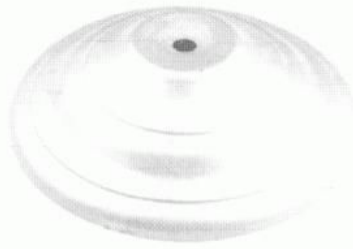

Art. 20028 ø 170 x h 48 spes. 0,8



Art. 20050 69 x 20 x sp. 1,5  
" 20051 90 x 20 x sp. 1,5  
" 20052 95 x 20 x sp. 1,5  
foro centrale ø 10,5  
fori laterali ø 5,5



100 x 20 x spes. 1,5  
Art. 20060 - 10/1  
" 20061 - 10/1 - 4ma



106 x 26 x spes. 1,5  
Art. 20070 - 10/1



118 x 26 x spes. 1,5  
Art. 20080 - 10/1

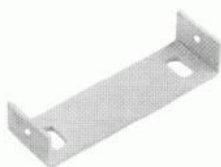

68 x 20 x spes. 1,5  
Art. 20150 - 4ma

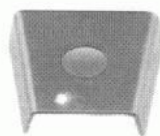

41 x 35  
Art. 20170

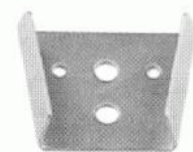

41 x 35  
Art. 20171

**BASE PIANA**

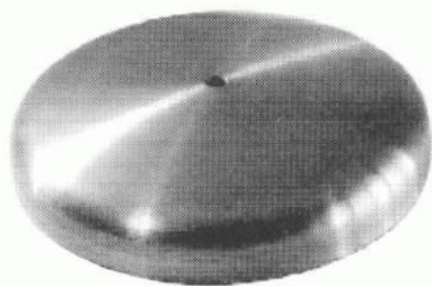

Art.	diam.	spessori disponibili	
20035	200	3,0 - 4,0	
20036	200	3,0 - 4,0	con foro laterale
20040	260	4,0 - 6,0	
20041	260	4,0 - 6,0	" " " "
20045	290	4,0 - 6,0	
20046	290	4,0 - 6,0	" " " "
20047	320	4,0 - 6,0 - 8,0	
20048	320	4,0 - 6,0 - 8,0	" " " "
20049	380	4,0 - 5,0	

**COPRIBASE PIANA**

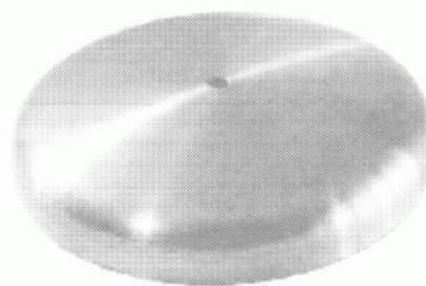

Art.	diam.
20535	200
20540	260
20545	290
20547	320

**BASE a LENTE**

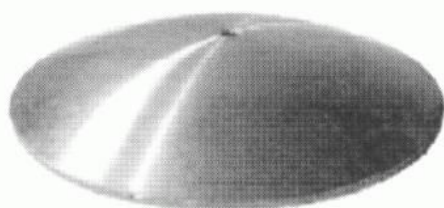

Art.	diam.	spessori disponibili
20620	200	3,0 - 4,0 - 6,0
20622	220	3,0 - 4,0 - 6,0
20625	250	4,0 - 6,0
20628	280	4,0 - 6,0
20630	300	4,0 - 6,0
20638	138 x h 30	2,0
20649	150 x h 32	1,5
20654	155 x h 19	2,0
20655	155 x h 20	3,0

**COPRIBASE a LENTE**

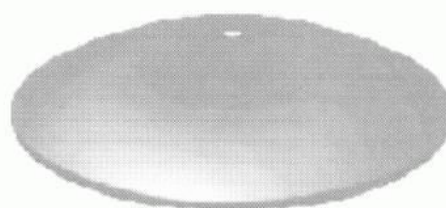

Art.	diam.
20720	200
20722	220
20725	250
XXXXX	xxx
20730	300

**BASE QUADRA**

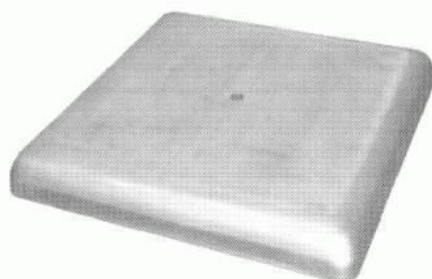

Art.	□	spessori disponibili
20815	150 x h 23	6,0
20820	200 x h 23	6,0
20825	250 x h 23	6,0

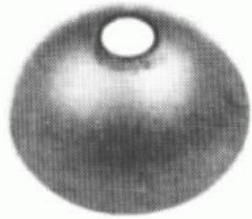

Art. 20082 ø 40 x h 20  
 " 20083 ø 60 x h 30  
 " 20084 ø 80 x h 40  
 " 20084 ø 80 x h 40 sp. 1,2  
 " 20085 ø 100 x h 50

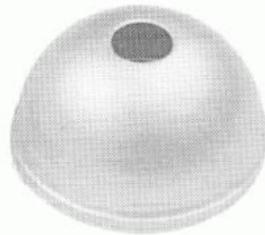

Art. 20094 ø 35 x h 17 con bordo  
 " 20096 ø 52 x h 29 " "  
 " 20098 ø 66 x h 34 " "

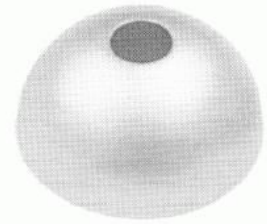

Art. 20095 ø 34 x h 17 senza bordo  
 " 20097 ø 50 x h 23 " "  
 " 20099 ø 64 x h 31 " "

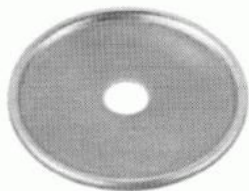

centrasfere

Art. 20077 per sfere ø 50  
 " 20078 per sfere ø 60  
 " 20079 per sfere ø 80



ø 14

Art. 20087



ø 19

Art. 20088



ø 36 x h 31

Art. 20090

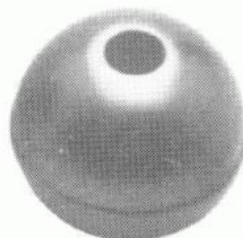

ø 45 x h 42

Art. 20091

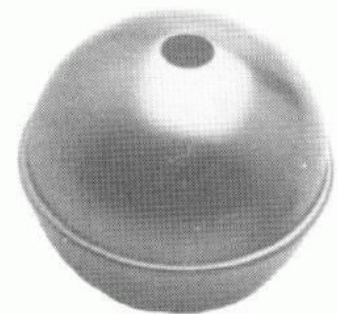

ø 68 x h 65

Art. 20092

# B A S E T T E

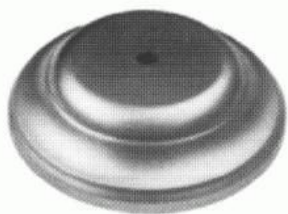

ø 120 x h 36  
Art. 20200

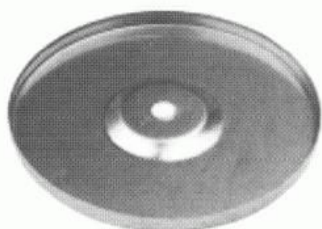

ø 116 x h 9      ø 136 x h 9  
Art. 20210      Art. 20230  
per art. 20200      per art. 20220

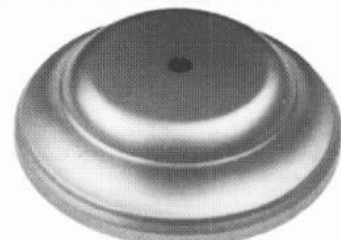

ø 140 x h 37  
Art. 20220

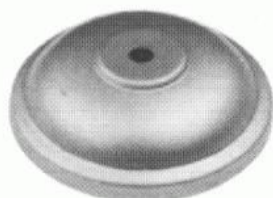

ø 110 x h 30  
Art. 20240

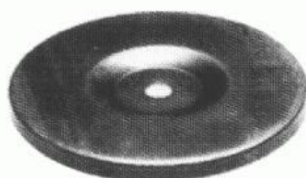

Art. 20215 ø 116 x h 9 sp. 2,0 x art. 20200  
x art. 20220  
Art. 20235 ø 136 x h 9 sp. 2,0 x art. 20280  
x art. 20290



ø 130 x h 40  
Art. 20245  
ribordata

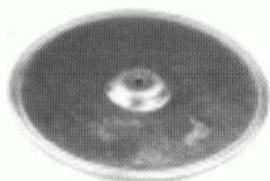

ø 108  
Art. 20250  
per art. 20240

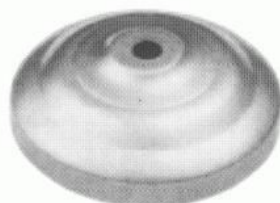

ø 109 x h 36  
Art. 20260

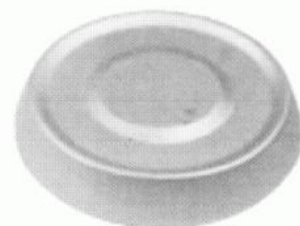

ø 115 x h 21  
Art. 20270

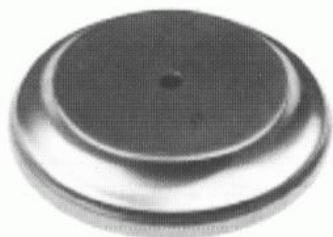

ø 140 x h 25  
Art. 20280



ø 140 x h 46  
Art. 20290



ø 110 x h 30  
Art. 20295  
c/ foro 10,5 + 2 fori per staffa

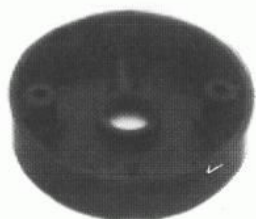

ø 75 x h 18  
Art. 20100  
plastica

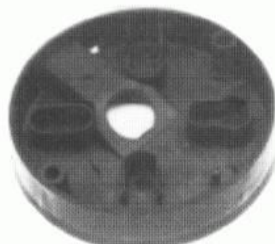

ø 102 x h 23  
Art. 20110  
plastica



mm 107 x 19 2 fori 4mazincata  
Art. 20296 per art. 20295



23 x 26 x h 5,5

ART. 21000



27 x 40 x h 19

Art. 21010

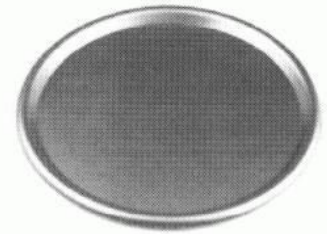

ø 225 x h 9

Art. 21025 senza foro  
" 21026 1 f. 4,0

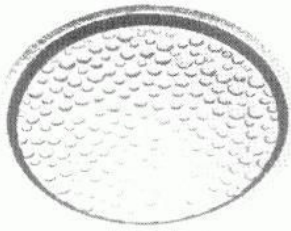

ø e 240 x ø i 205 x h 8

Art. 21030 bollinato  
" 21031 liscio



ø e 240 x ø i 205 x h 8

Art. 21032 rigato

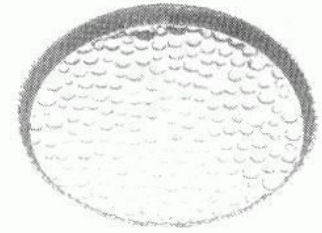

ø e 226 x ø i 205 x h 18

Art. 21040 bollinato  
" 21041 liscio

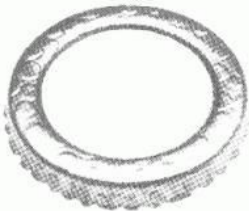

ø 125 x h 18

Art. 21055 1 f. 84,0  
bollinato

Art. 21056 1 f. 84,0  
liscio

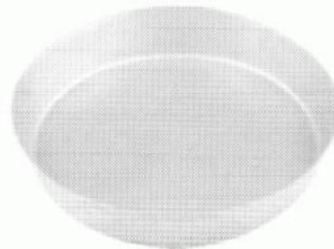

Art. 21060 ø e 167 x ø i 150  
" 21061 ø e 140 x ø i 120  
" 21071 ø e 120 x ø i 95  
svasati

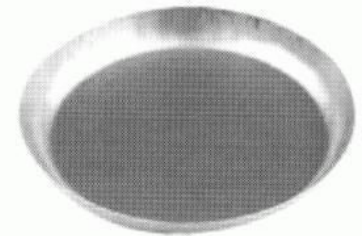

Art. 21070 ø e 163 x ø i 135  
" 21072 ø e 130 x ø i 100  
" 21073 ø e 195 x ø i 150  
concavi

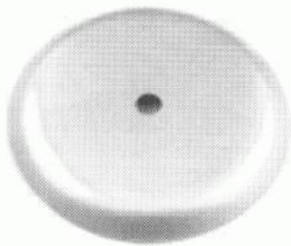

ø 115 x h 11

Art. 21074

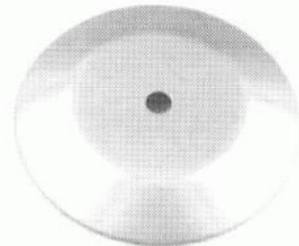

ø 117 x h 13

Art. 21075

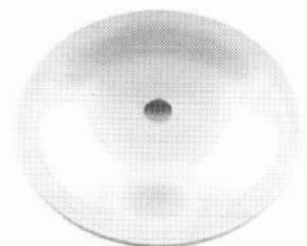

Art. 21076 ø 204 x h 18,0 sp. 2,0 s/foro  
" 21076 ø 204 x h 18,0 " 2,0 f. 5,0  
" 21077 ø 76 x h 5,0 " 2,0 s/foro  
" 21077 ø 76 x h 5,0 " 2,0 f. 10,0  
" 21078 ø 106 x h 9,0 " 2,0 f. 10,0  
" 21079 ø 128 x h 12,0 " 2,0 f. 10,0

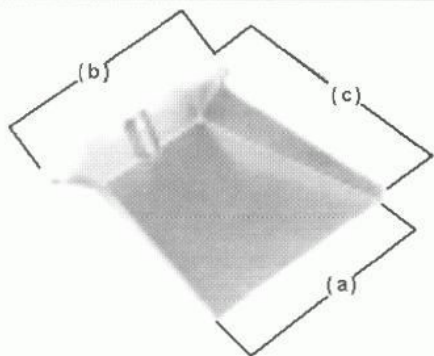

	(a)	(b)	(c)	spes.
Art. 21080	90	108	126	0,8
" 21081	124	121	129	1,0
" 21083	124	131	129	0,8



ø 83 x h 12 1f. 3,0 + cava

Art. 21200

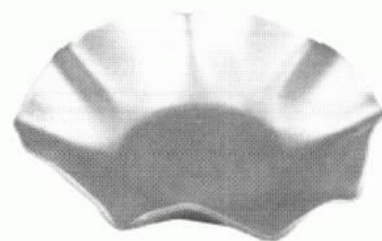

ø 210 x h 45 spes. 3,0

Art. 21300



134 x 101 x 160 x h 18

Art. 21090

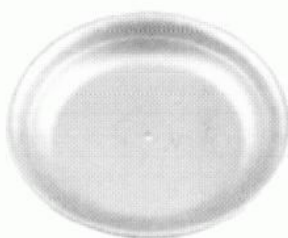

ø 118 x h 18 1f. 3,0

Art. 21210

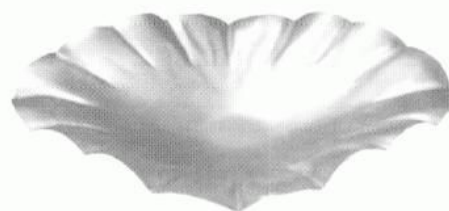

270 x 190 x h 49

Art. 21305

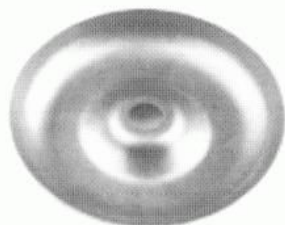

Art. 21220	ø 90	x h 12	c/foro	spes. 0,7
" 21221	" x "	"	s/foro	" 0,7
" 21230	" x "	"	c/foro	" 1,0
" 21231	" x "	"	s/foro	" 1,0

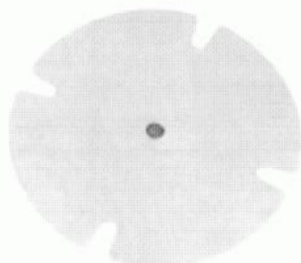

ø 158 spes. 1,5 1f. 12,3

Art. 21350

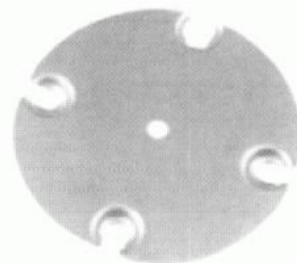

ø 158 spes. 1,5 1f. 12,3

Art. 21351



Art. 23000	ø 35	x h 90	∅ 8 x 8
" 23010	" 45	x h 110	" 10 x 10
" 23020	" 60	x h 150	" 12 x 12
" 23030	" 63	x h 155	" 14 x 14
" 23040	" 70	x h 160	" 16 x 16
" 23050	" 90	x h 120	" 20 x 20
" 23060	" 110	x h 210	" 24 x 24
" 23070	" 115	x h 240	" 30 x 30

Art. 23100	ø 65	x h 150	∅ 12 x 12
" 23110	" 95	x h 185	" 24 x 24
" 23120	" 125	x h 240	" 30 x 30

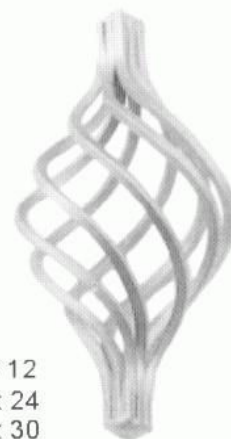

	catena    tigetta    gancio    materiale    accessori					lunghezza tutto compresa
		Art. 24000	gen. ø 2,8 + art. 230	+ art. 1270	ferro grezzo	senza forellino
" 24010		" " " + " "	+ " 1271	" "	con vite montata	" "
	Art. 24030	gen. ø 2,8 + art. 230	+ art. 1283	ottone	senza forellino	cm. 50
	" 24040	" " " + " "	+ " "	"	con vite montata	" "
	Art. 24060	gen. ø 2,8 + art. 230	+ art. 1286	ferro grezzo	senza forellino	cm. 50
	" 24070	" " " + " "	+ " "	" "	con vite montata	" "
	Art. 24100	gen. ø 2,8 + art. 230	+ art. 1288	ferro grezzo	con vite montata + blocca cavo	cm. 50
	Art. 24200	gen. ø 3,8 + art. 230	+ art. 1270	ferro grezzo	senza forellino	cm. 50
	" 24210	" " " + " "	+ " "	" "	con vite montata	" "
	Art. 24230	gen. ø 3,8 + art. 230	+ art. 1283	ottone	senza forellino	cm. 50
	" 24240	" " " + " "	+ " "	"	con vite montata	" "
	Art. 24260	gen. ø 3,8 + art. 230	+ art. 1286	ferro grezzo	senza forellino	cm. 50
	" 24270	" " " + " "	+ " "	" "	con vite montata	" "
	Art. 24300	gen. ø 3,8 + art. 230	+ art. 1288	ferro grezzo	con vite montata + blocca cavo	cm. 50
	Art. 24600	ritorta 3,8 + art. 230	+ art. 1270	ferro grezzo	senza forellino	cm. 50
	" 24610	" " " + " "	+ " "	" "	con vite montata	" "
	Art. 24630	ritorta 3,8 + art. 230	+ art. 1283	ottone	senza forellino	cm. 50
	" 24640	" " " + " "	+ " "	"	con vite montata	" "
	Art. 24660	ritorta 3,8 + art. 230	+ art. 1286	ferro grezzo	senza forellino	cm. 50
	" 24670	" " " + " "	+ " "	" "	con vite montata	" "
	Art. 24700	ritorta 3,8 + art. 230	+ art. 1288	ferro grezzo	con vite montata + blocca cavo	cm. 50
	Art. 24800	gen. ø 2,8 + art. 230				cm. 50
	" 24850	gen. ø 3,8 + art. 230				cm. 50
	" 24960	ritorta 3,8 + art. 230				cm. 50



**CATENA GENOVESE FILO TONDO**

Art.	filo ∅	interna maglia	n. anelli per metro
25000	2,2	6x16	62
25010	2,5	11x31	32
25020	2,8	10x34	30
25030	3,0	8x24	42
25040	3,0	10x30	33
25050	3,5	10x30	33
25060	3,5	15x43	23
25070	3,8	12x40	25
25080	3,8	12x34	30
25090	4,8	15x45	22



**CATENA GENOVESE FILO RITORTO**

Art.	filo ∅	interna maglia	n. anelli per metro
25100	3,0	11x40	25
25110	3,5	12x40	25
25120	5,0	15x55	18



**CATENA GENOVESE FILO QUADRO**

Art.	filo ∅	interna maglia	n. anelli per metro
25200	3,5	12x40	25
25210	5,0	15x43	23
25220	5,7	15x60	17
25225	5,7	15x60	17 schiacciata



**CATENA CATTEDRALE FILO QUADRO**

Art.	filo ∅	interna maglia	n. anelli per metro
25300	2,2	10x25	40
25310	2,7	14x40	25
25320	3,0	14x40	25
25330	3,5	19x45	22
25340	3,8	19x45	22
25350	5,0	20x50	20

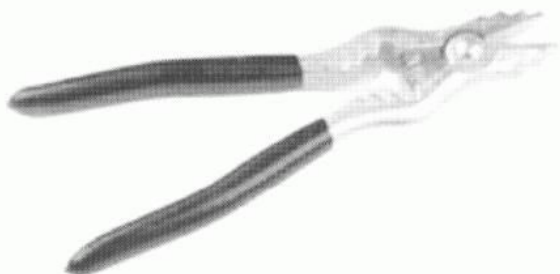

**Art. 25999**  
pinza per catena



Art.	filo ∅	foro ∅ i	Art.	filo ∅	foro ∅ i
26000	3,0	8	26070	5,0	20
26010	3,0	10	26080	5,0	30
26020	3,0	14	26085	5,0	40
26030	3,0	20	26090	6,0	14
26040	4,0	10	26100	6,0	25
26050	4,0	30	26105	6,0	30
26060	5,0	10	26110	6,0	40

FILO FERRO TONDO LISCIO



Art.	filo ∅	foro ∅ i
26200	3,5	30
26210	5,0	63

FILO FERRO QUADRO RITORTO



Art.	filo ∅	foro ∅ i
26300	6,0	25
26301	6,0	30
26310	6,0	40
26320	6,0	50
26330	6,0	55
26340	6,0	63

FILO FERRO QUADRO MARTELLINATO

*N.B.: si può fornire catena ad anelli martellinati.*

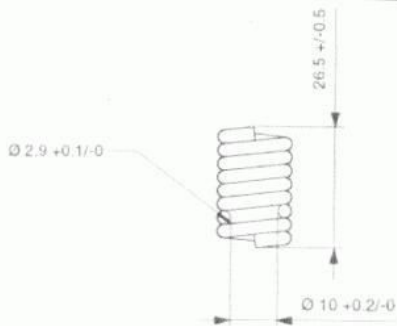

Art. 31110

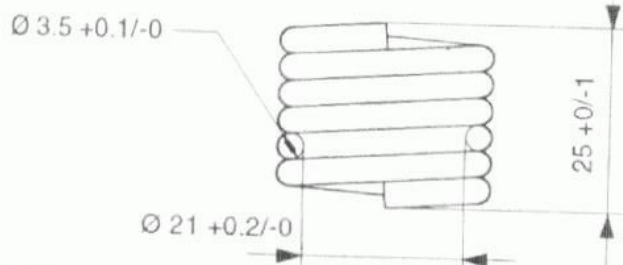

Art. 31120

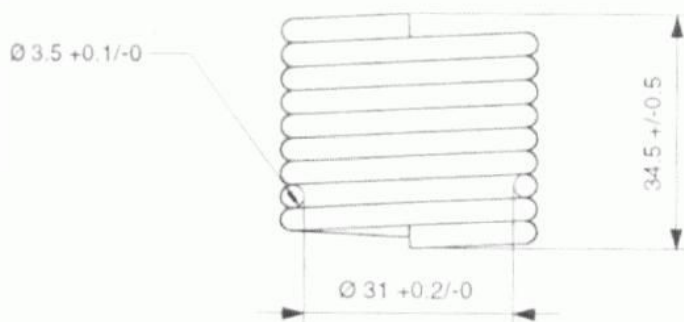

Art. 31130

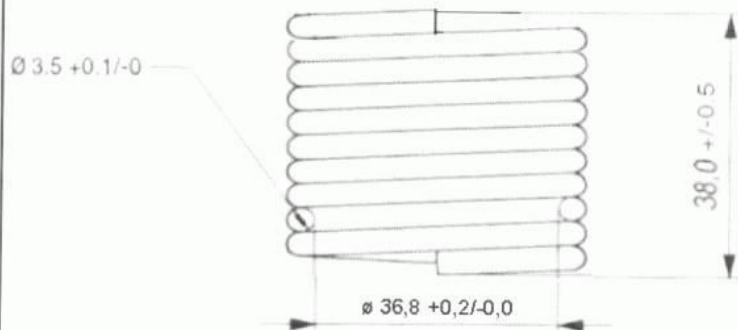

Art. 31140

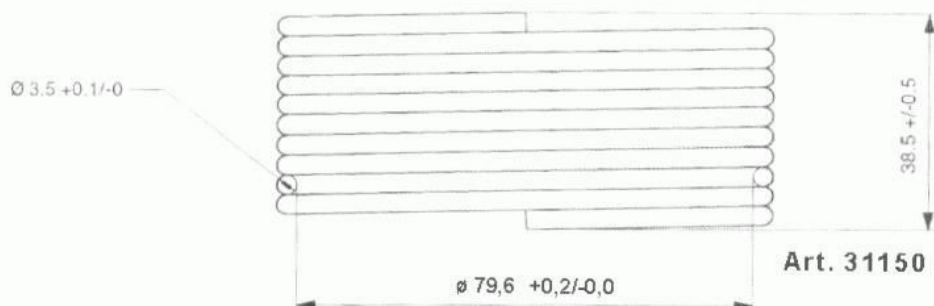

Art. 31150

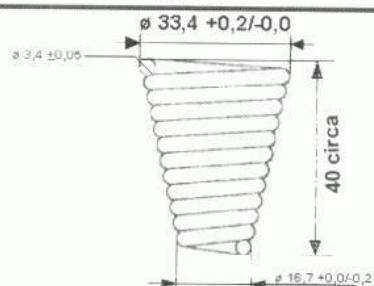

Art. 31160

## Articolo      brevettato

Formata da due soli pezzi, non necessita di complicate procedure di montaggio. Vi è la possibilità di montare un interruttore "filo" e di posizionare il portalamпада su tre inclinazioni [0° - 45° 90°], consentendo così l'utilizzo di lampade diverse sia per forma sia per dimensioni.

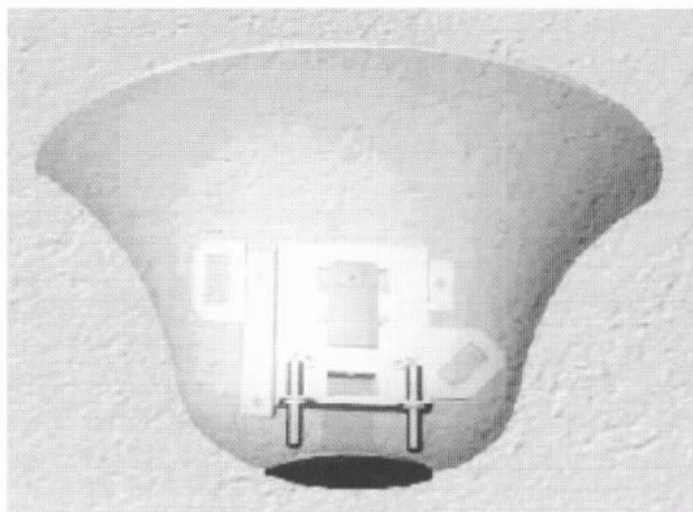
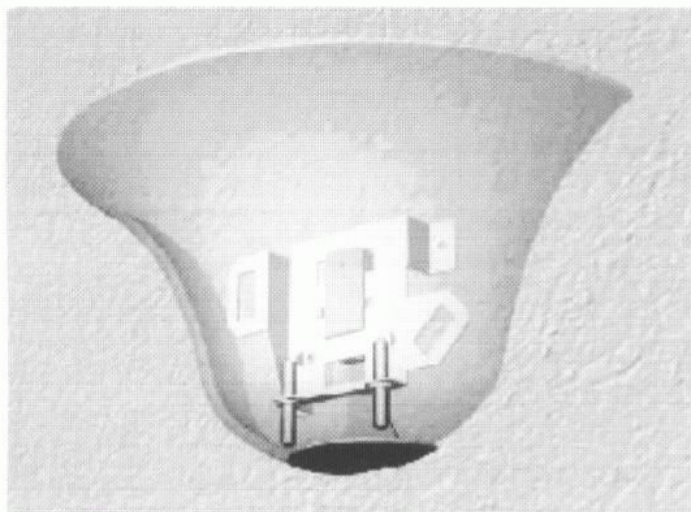

Alloggiamento per interruttore

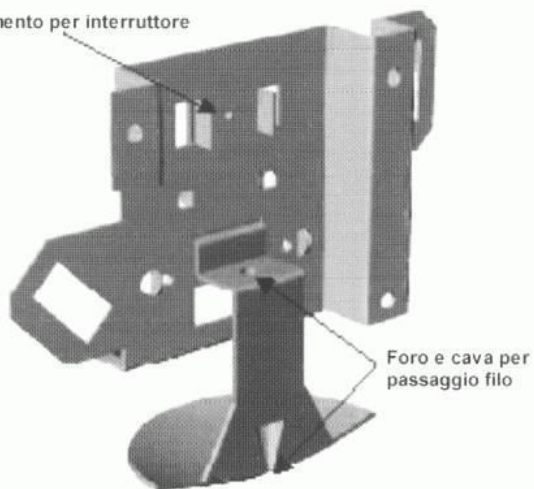

Foro e cava per passaggio filo

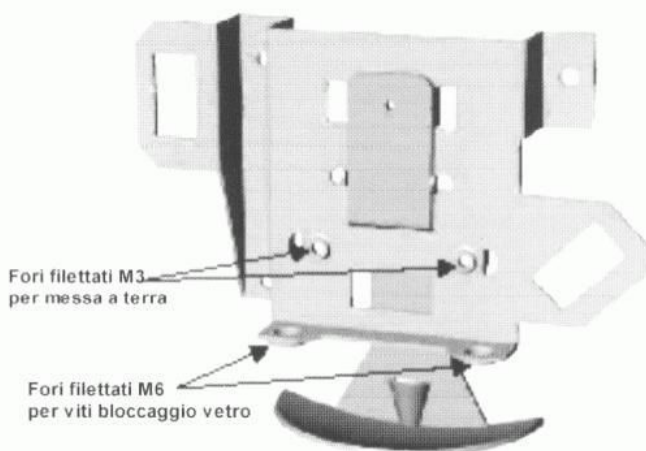

Fori filettati M3 per messa a terra

Fori filettati M6 per viti bloccaggio vetro

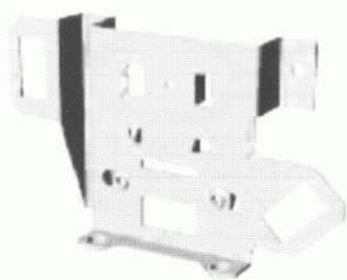

mm. 125 x 74 x h 30

**Art 31500**

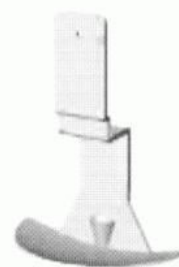

mm. 91 x 65 x h 33

**Art 31510**

*Piccoli dettagli che fanno  
Grande la Qualità italiana e il Design  
dei nostri Prodotti*

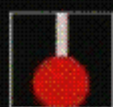
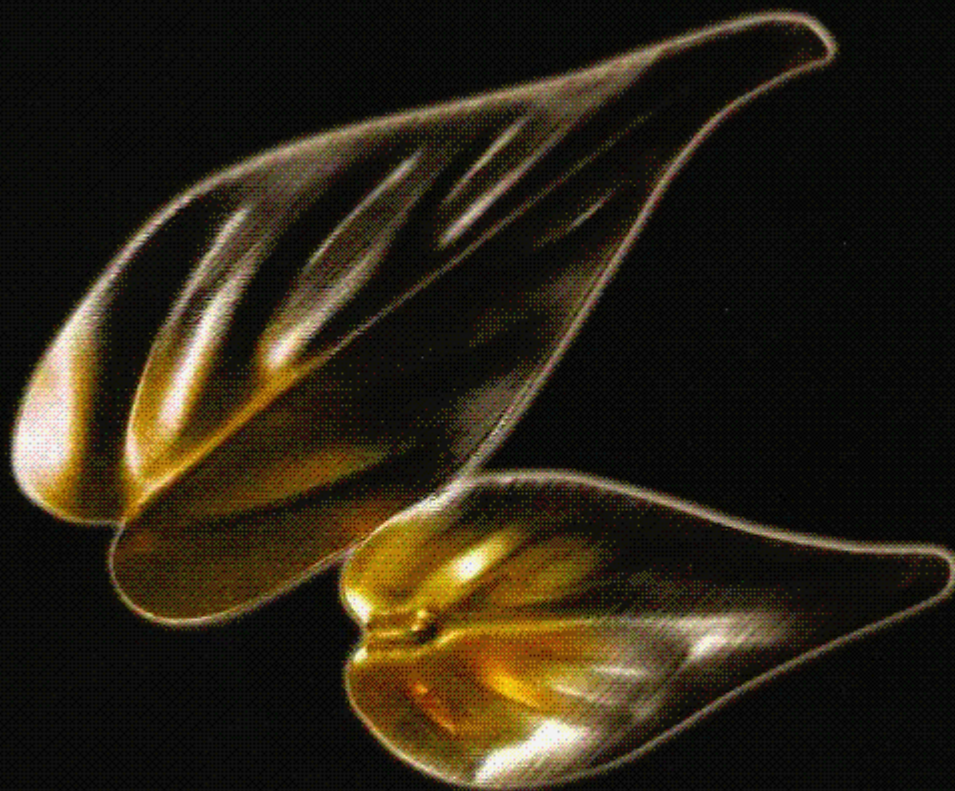

**FAMPLA**

ACCESSORI E MINUTERIE PER LAMPADARI

REPRESENTADA EM PORTUGAL POR:



Tel. +351 927 824 951  
Fax +351 224 225 712

Tv. Padre António Lino S. Vale, E.10 – 1º  
4440-754 Valongo - PORTUGAL

Web: [www.adlucem.com](http://www.adlucem.com)  
E-mail: [info@adlucem.com](mailto:info@adlucem.com)